

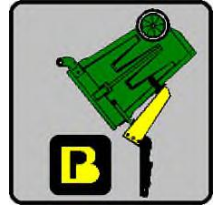

BP LIFTS

By Barker Products
1310 Miller Road, Greenville, SC 29607
Phone:800-349-3149—Fax:864-297-1292



Model BPC-612HDN 44 LIFT



- Meets ANSI Z245 Type B Specifications
- Powered By a 3" Bore Hydraulic Cylinder With Cushions On Both Ends
- Made for Heavy Duty High Lift Applications
- Mounting Height—44" To Top of Mounting Plate
- EZ Bolt On Kit Standard
- Heavy Duty Cast Iron Bushings For Long Life Cycle
- Kickout Feature Protects Lifter From Ground Damage
- Modular Bolted Construction For Ease Of Part Replacement
- Non Adjustable Lower Hook Linkage



1310 Miller Road
Greenville, SC 29607

Lift

Barker Products

Unit Specialist



Phone: 864-288-7384
Fax: 707-371-4886

BPC-612HDN44 LIFT UNIT SPECIFICATIONS

1 MOUNTING BRACKET:

Unit will be bolted to mounting bracket for ease of repair or replacement. In the event of truck settling, unit height must be adjustable in 1" increments to 2" total.

2 HYDRAULIC CYLINDER:

Non adjustable cushions on both ends.

3 CART LIFTING CAPABILITY:

ANSI Type B (American 2 bar cart)

4 Major Pivot Points:

All major pivot points are 1 1/4" diameter and equipped with heavy duty cast iron bushings and "Zerk" type grease fittings.

5 IMPACT RELEASE DEVICE:

The unit has a mechanical kickout feature that allows the unit to release from the vertical (down) position when struck by the street surface while the truck is in forward motion. When fully activated the vertical ground clearance is improved by five (5) inches. Unit must reset automatically to lift position.

6 LIFT BAR POCKET:

The lift bar pocket (saddle) is designed to minimize cart free movement when unit is in the up position. Bolted on for ease of replacement if damaged.

7 MOUNTING HEIGHT:

With the truck in "Level" position, the measurement from the top of the mounting plate to ground level will be 43 to 45 inches.

Note: User preferences vary, so mounting height should be approved by the end user.

8 DUMP ANGLE:

The lift plate when fully raised, will be at no less than 140 degrees inclusive.

9 LIFT PLATE (SHELL):

Constructed of 1/4" thick steel plate. Bolted on for ease of replacement if damaged. The lift plate will be painted safety yellow.

10 HOOK (LOWER BAR LATCH):

Mechanically operated by double non-adjustable steel linkage to securely hold the cart in place even if it is shaken at the top. Rotating style with replaceable bushings mounted on 3/4" diameter steel shaft. No sliding surfaces to wear out. Pivot points are bolted to the lift plate for ease of replacement if damaged.

11 CART LIFTING CAPACITY:

The unit will lift a minimum of 350 pounds at 1200 PSI hydraulic pressure.

12 PACKER BLADE INTERFERENCE:

When mounted properly, the unit can not be hit by the packer blade.



Barker Products
1310 Miller Road, Greenville, SC 29607



BPC-612HDN44

Envelope Dimensions

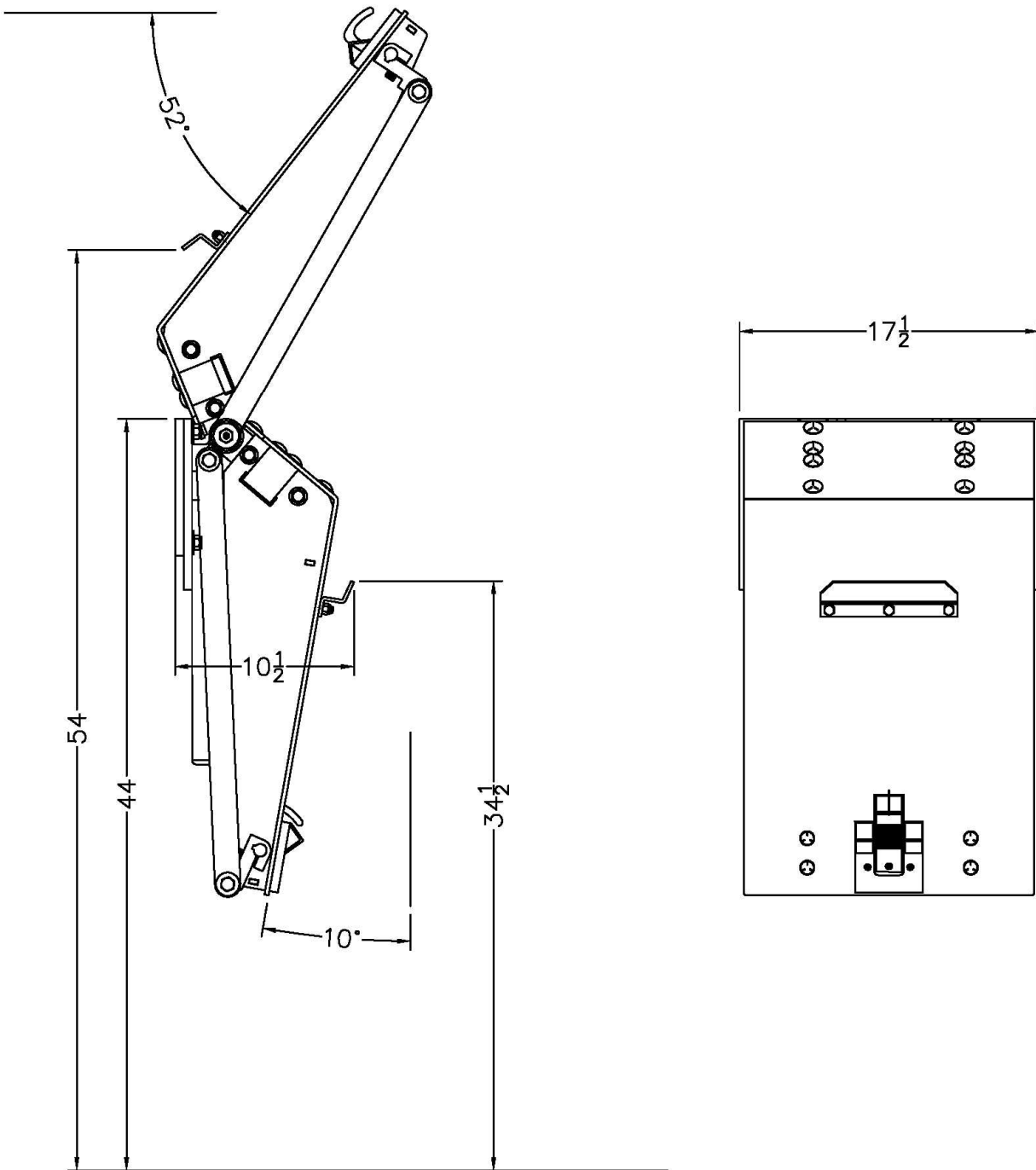

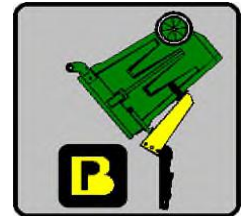
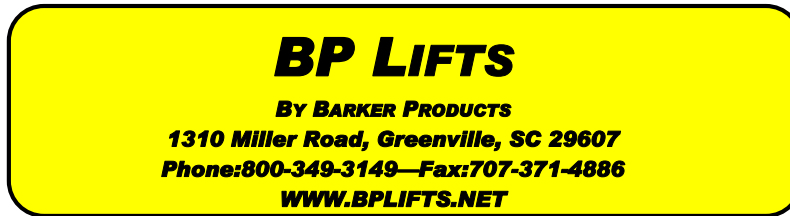

Lift Unit Installation

1. Truck must be empty, clean and parked on a level surface before installation is started.
2. Remove all bumpers and running boards that will interfere with the location of the lift units. Relocate lower mounted tail lights as needed.
3. Measure and mark the centerline of the truck hopper. The centerline of the unit or units should be a minimum of 17" from the hopper centerline.
4. Hand valves should be mounted on the side of the hopper at the most convenient height for the operator and clear of the packer controls.
5. The top of the unit mounting plate should be tack welded in place at the height recommended on the envelope dimension sheet of the unit.
CAUTION: SEE NOTE BELOW PICTURE
6. All dimensions should be approved by the customer before final welding.
7. If the mounting plate extends more than 2" above the hopper, a brace should be added.

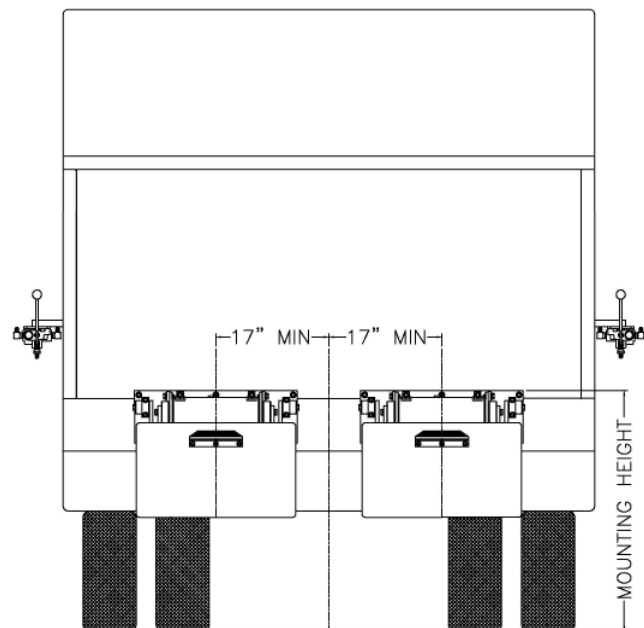

Mounting heights and locations are recommendations only. It is the responsibility of the installer to insure that the customer is satisfied with the height. Barker Products recommends that after the units are tacked in place, try the units with the can or cans the customer uses. The customer should approve your mount before final welding.



1310 Miller Road
Greenville, SC 29607

Barker Products

Lift Unit Specialist



Phone: 864-288-7384
Fax: 864-297-1292

BPC-612 LIFT UNIT WARRANTY

Barker Products warranties each new dump unit to be free of defects in material and workmanship under normal use and service for a period of 1 year or 2000 hours of operation, whichever comes first, from the date of delivery.

This warranty excludes any obligations by BARKER PRODUCTS for the cost of down time. BARKER PRODUCTS will not warranty any dump unit which has been subject to misuse, neglect, alteration, or damaged by an accident.

On any work not performed by BARKER PRODUCTS or it's representative, the customer will be responsible for freight charges on all parts shipped under warranty. Parts will be invoiced at time of shipment. Defective parts must be returned to BARKER PRODUCTS within 30 days. If the part is determined to be defective the customer will be credited for the original invoice.

Customer warranty labor charges must be approved by BARKER PRODUCTS in advance. If not contacted for approval, BARKER PRODUCTS will not be liable for the warranty labor charge.

ITEM NO.	PART NUMBER	DESCRIPTION	QTY.
1	BWA17520	MAINFRAME SUB ASSY	1
2	BWA17534	LIFT PLATE SUB ASSY	1
3	BW17625	HOOK LINK	2
4	XEA082412SS	FLAT WASHER 1/2X11/2X1/8	4
5	XAA081316	1/2-13 X 2 HHCS	4
6	XDA081300	1/2-13 HEX NUT	4
7	BWA17620	HOOK SUB ASSY	1
8	BW99308	1/2" SPHERICAL BEARING	4
9	BWA17450	CYLINDER SUB ASSY	1

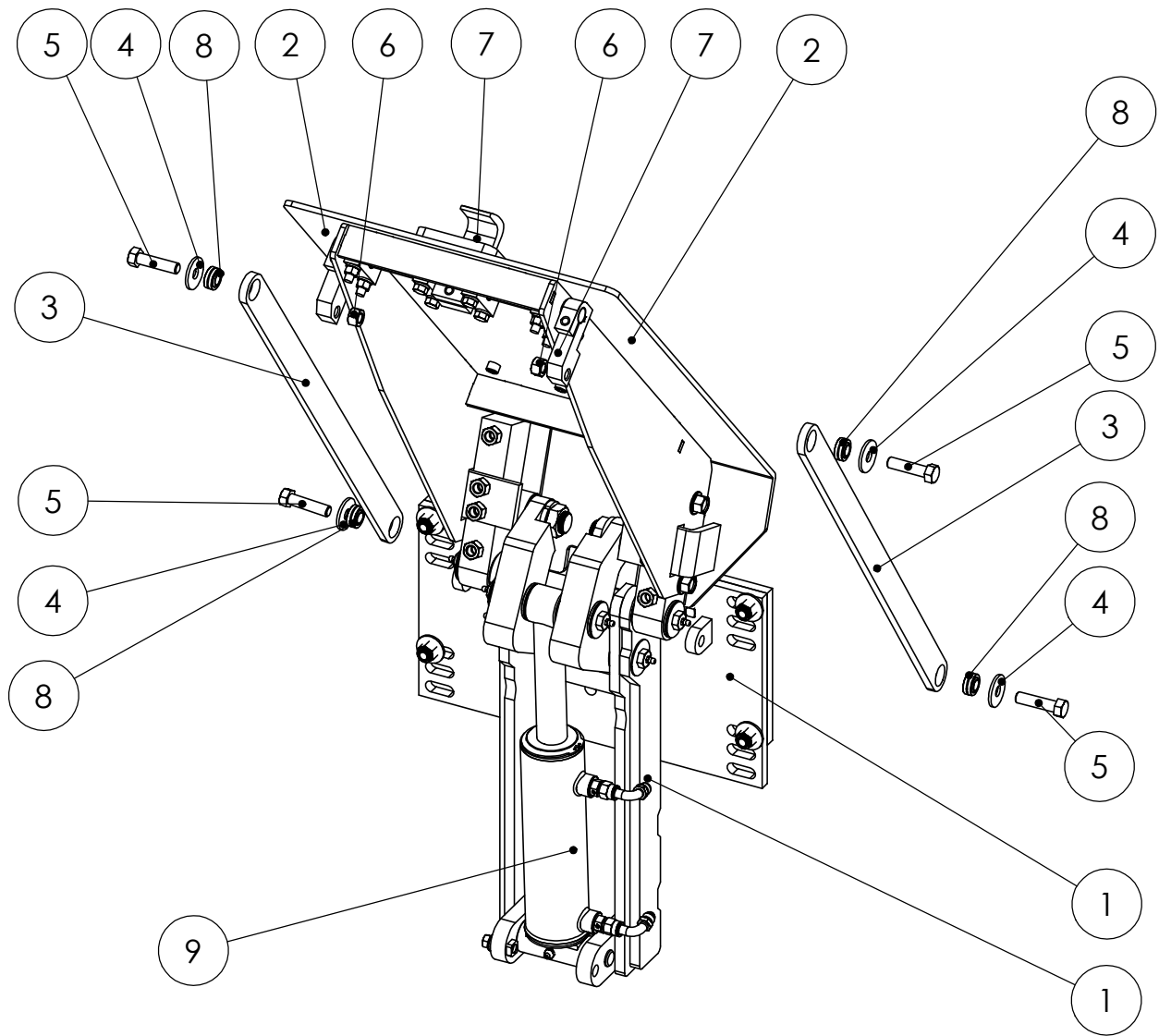

DO NOT SCALE DRAWING		612HDN44 LIFT PARTS	
UNLESS OTHERWISE SPECIFIED: DIMENSIONS ARE IN INCHES TOLERANCES: FRACTIONAL ±1/32 ANGULAR: MACH ±1° BEND ±1° TWO PLACE DECIMAL ±0.010 THREE PLACE DECIMAL ±0.005		DRAWING NO BU03944 PARTS	REV 00
SCALE: 1:8		WEIGHT: 201.810 #	SHEET 1 OF 1



BARKER PRODUCTS
1310 MILLER ROAD
GREENVILLE, SC
29607

DRAWN BY: R WYMAN
DATE: 11/10/2023
MATERIAL: NOTED

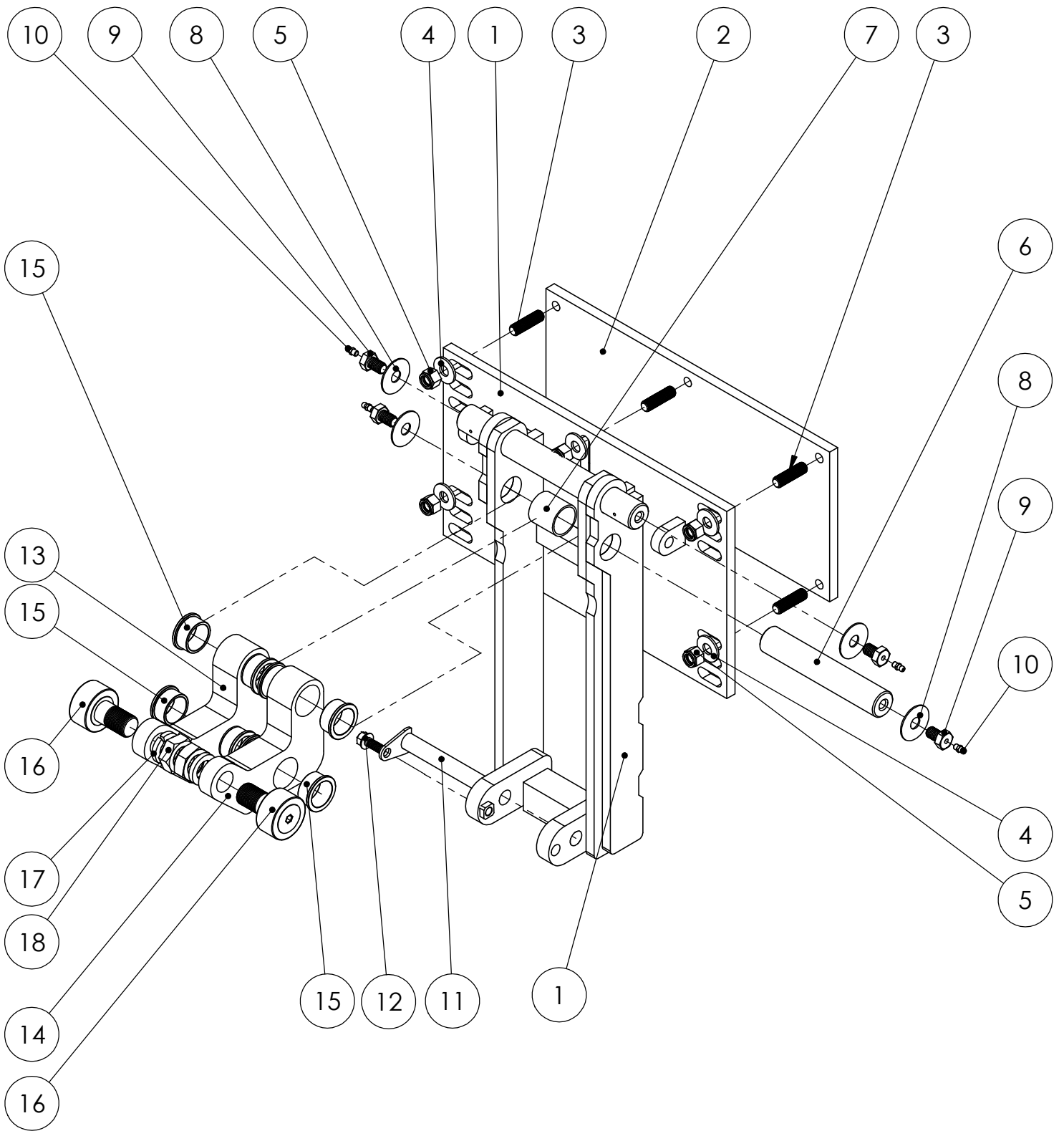

BARKER PRODUCTS
 1310 MILLER ROAD
 GREENVILLE, SC
 29607

DRAWN BY: R WYMAN
 DATE: 9/21/2017
 MATERIAL: NOTED

DO NOT SCALE DRAWING		MAINFRAME SUB ASSY PARTS 612	
UNLESS OTHERWISE SPECIFIED: DIMENSIONS ARE IN INCHES TOLERANCES: FRACTIONAL $\pm 1/32$ ANGULAR: MACH $\pm 1^\circ$ BEND $\pm 1^\circ$ TWO PLACE DECIMAL ± 0.010 THREE PLACE DECIMAL ± 0.005		DRAWING NO BWA17520 PARTS	REV 00
SCALE: 1:6	WEIGHT: 98.968 #	SHEET 1 OF 2	

ITEM NO.	PART NUMBER	DESCRIPTION	EXPLODED/QTY.
1	BW17520	MAINFRAME	1
2	BW17525	MOUNT PLATE - N	1
3	BW07140	PLATE STUD	5
4	XEA081000	1/2" FLAT WASHER	5
5	XDC081300	1/2-20 NYLOK NUT	5
6	BW17600	LIFT LINK SHAFT	1
7	BW00770	LIFT LINK SPACER	1
8	BW07115	BEARING CAP WASHER	4
9	BW07110	BEARING CAP BOLT	4
10	BW01110	GREASE FITTING - 1/4-28 SHORT	4
11	BW03050	CYLINDER MOUNT PIN	1
12	XAE061608	3/8-16 X 1 FLANGED HHCS	1
13	BW17550	LEFT LIFT LINK	1
14	BW17560	RIGHT LIFT LINK	1
15	BW00934	CAST FLANGE BUSHING	8
16	BW99030	1 7/8 CAM FOLLOWER	2
17	XEB161000	1" LOCKWASHER	2
18	XDB161400	1"-14 HEX JAM NUT	2



BARKER PRODUCTS
1310 MILLER ROAD
GREENVILLE, SC
29607

DRAWN BY: R WYMAN
DATE: 9/21/2017
MATERIAL: NOTED

DO NOT SCALE
DRAWING
UNLESS OTHERWISE SPECIFIED:
DIMENSIONS ARE IN INCHES
TOLERANCES:
FRACTIONAL ±1/32
ANGULAR: MACH ±1° BEND ±1°
TWO PLACE DECIMAL ±0.010
THREE PLACE DECIMAL ±0.005

MAINFRAME SUB ASSY PARTS
612

DRAWING NO
BWA17520 PARTS

REV
00

SCALE: 1:1 WEIGHT: 98.968 # SHEET 2 OF 2

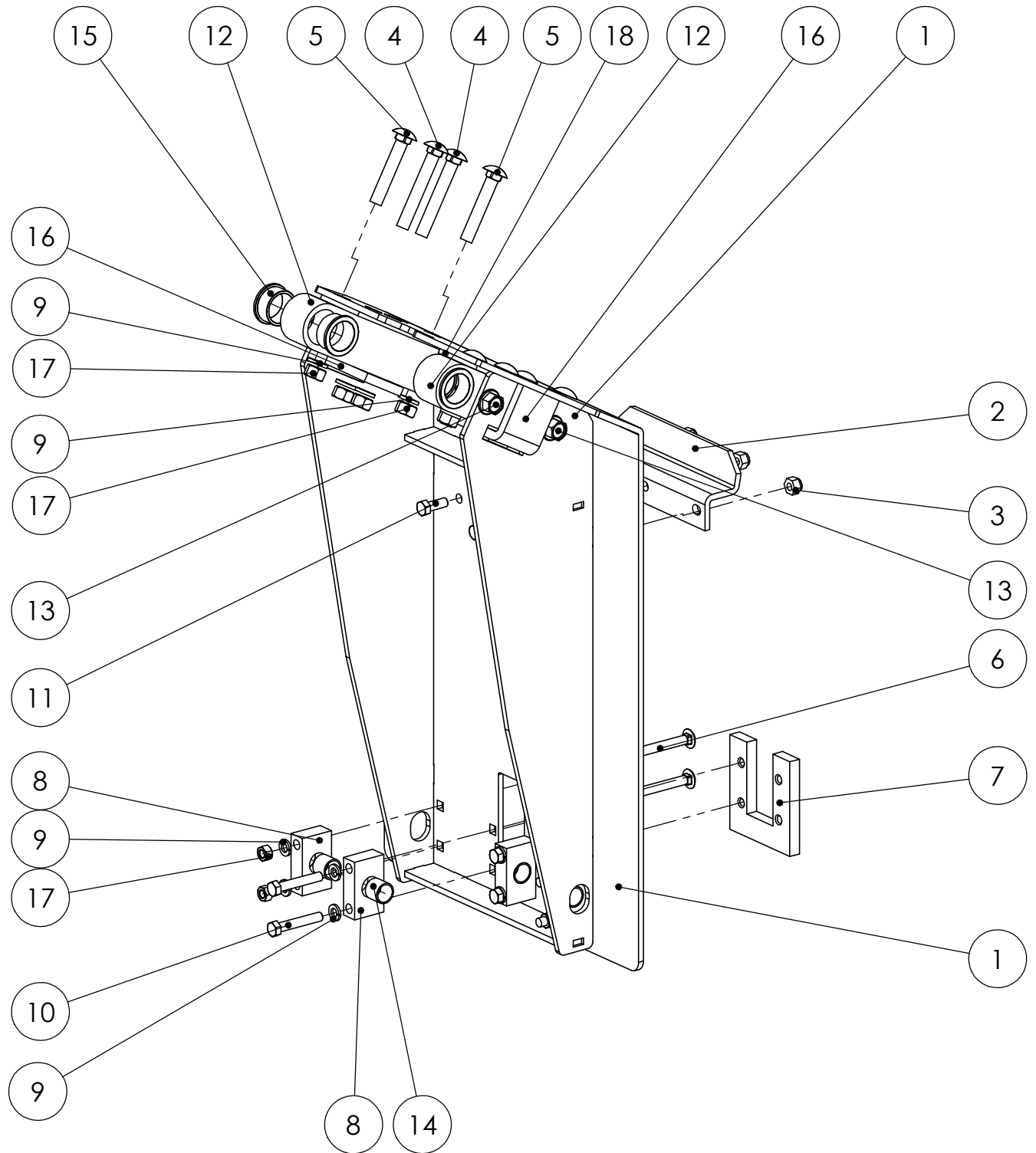

BARKER PRODUCTS
 1310 MILLER ROAD
 GREENVILLE, SC
 29607

DRAWN BY: R WYMAN
 DATE: 9/27/2017
 MATERIAL: NOTED

DO NOT SCALE
 DRAWING
 UNLESS OTHERWISE SPECIFIED:
 DIMENSIONS ARE IN INCHES
 TOLERANCES:
 FRACTIONAL $\pm 1/32$
 ANGULAR: MACH $\pm 1^\circ$ BEND $\pm 1^\circ$
 TWO PLACE DECIMAL ± 0.010
 THREE PLACE DECIMAL ± 0.005

LIFT PLATE SUB ASSY PARTS 612HDN44		REV 00
DRAWING NO BWA17534 PARTS		
SCALE: 1:6	WEIGHT: 73.981 #	SHEET 1 OF 2

ITEM NO.	PART NUMBER	DESCRIPTION	EXPLODED/QTY.
1	BW17534	LIFT PLATE	1
2	BW00800	SADDLE	1
3	XDC061600	3/8-16 NYLOK NUT	3
4	XAH081328	1/2-13 X 3 1/2 CARRIAGE BOLT	4
5	XAH081324	1/2-13 X 3 CARRIAGE BOLT	4
6	XAH061620	3/8-16 X 2 1/2 CARRIAGE BOLT	4
7	BZ03451	SUPPORT PLATE	1
8	BW17130	HOOK BEARING MOUNT	4
9	XEB061000	3/8 LOCKWASHER	16
10	XAA061620	3/8-16 X 2 1/2 HHCS	4
11	XAA061608	3/8-16 X 1 HHCS	7
12	BW17570	TRACK BAR	2
13	XAE081308	3/8-16 X 1 FLANGED HHCS	4
14	BW03195	12-DU-12 BEARING	4
15	BW00934	CAST FLANGE BUSHING	4
16	BW17595	TRACK CAP	2
17	XDA061600	3/8-16 HEX NUT	12
18	BW17580	TRACK PLATE 612	2



BARKER PRODUCTS
1310 MILLER ROAD
GREENVILLE, SC
29607

DRAWN BY: R WYMAN
DATE: 9/27/2017
MATERIAL: NOTED

DO NOT SCALE DRAWING		LIFT PLATE SUB ASSY PARTS 612HDN44	
UNLESS OTHERWISE SPECIFIED: DIMENSIONS ARE IN INCHES TOLERANCES: FRACTIONAL ±1/32 ANGULAR: MACH ±1° BEND ±1° TWO PLACE DECIMAL ±0.010 THREE PLACE DECIMAL ±0.005		DRAWING NO BWA17534 PARTS	REV 00
SCALE: 1:1	WEIGHT: 73.981 #	SHEET 2 OF 2	

ITEM NO.	PART NUMBER	DESCRIPTION	EXPLODED VIEW/QTY.
1	BW17450	CYLINDER 2 1/2 X 6	1
2	BW07115	BEARING CAP WASHER	2
3	BW07110	BEARING CAP BOLT	2
4	BW01110	GREASE FITTING - 1/4-28 SHORT	2
5	BR03830	6400-06-06 M TUBE O-RING	1
6	BV00020	093 X 1/8 NPT ORIFICE PLUG	1
7	BV00064	6T X 6S ORIFICE FITTING	1
8	BR05106	6701-06-06 M37 X FS37	2

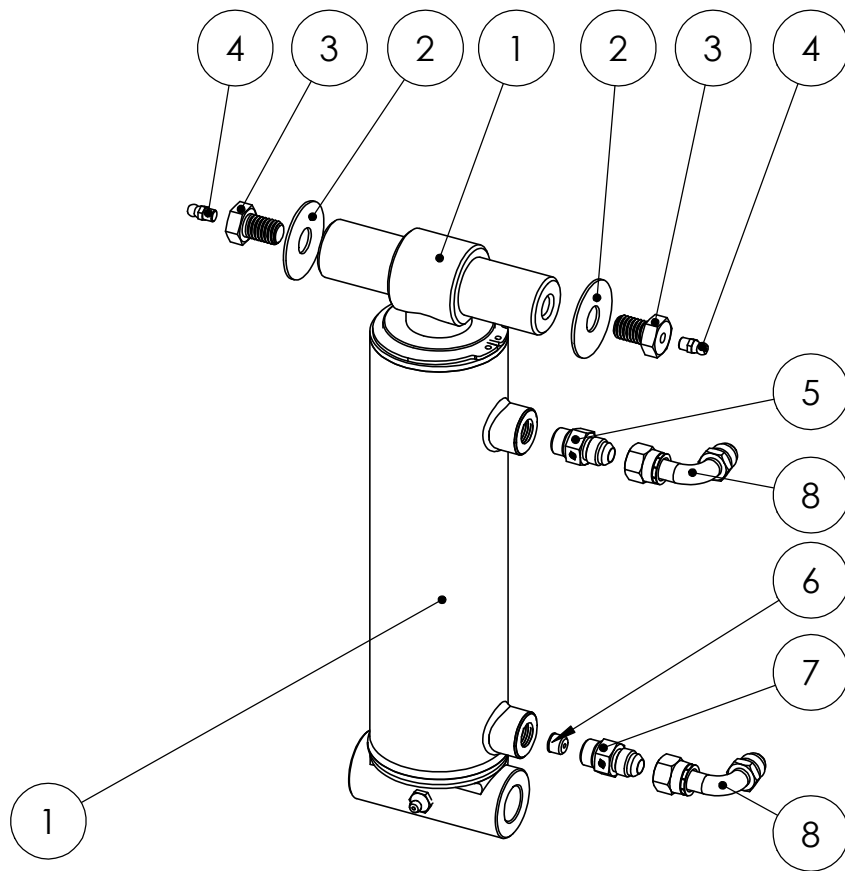

<p>DO NOT SCALE DRAWING</p> <p>UNLESS OTHERWISE SPECIFIED: DIMENSIONS ARE IN INCHES TOLERANCES: FRACTIONAL ±1/32 ANGULAR: MACH ±1° BEND ±1° TWO PLACE DECIMAL ±0.010 THREE PLACE DECIMAL ±0.005</p>	<p>CYLINDER SUB ASSY 612 N - 2 1/2 BORE</p>		<p>REV 00</p>
	<p>DRAWING NO BWA17450 PARTS</p>	<p>SCALE: 1:4 WEIGHT: 12.213 # SHEET 1 OF 1</p>	



BARKER PRODUCTS
1310 MILLER ROAD
GREENVILLE, SC
29607

DRAWN BY: R WYMAN
DATE: 1/8/2019
MATERIAL: NOTED