



BP LIFTS

BY BARKER PRODUCTS
1310 Miller Road, Greenville, SC 29607
Phone:800-349-3149—Fax:864-297-1292



Model BPH-15 Series Lifts



- **Meets ANSI Z245 Type B Specifications**
- **Powered By The Dependable Smooth Acting Helical Rotary Actuator**
- **Splined Shafts To Eliminate Arm Movement And Wear**
- **EZ Bolt On Kit Standard**
- **Heavy Duty Cast Iron Bushings For Long Lift Cycle**
- **36" To 48" Mounting Heights Available**
- **16" Ground Clearance**



1310 Miller Road
Greenville, SC 29607

Barker Products

Lift Unit Specialist



Phone: 864-288-7384
Fax: 864-297-1292

BPH SERIES LIFT UNIT SPECIFICATIONS

THE FOLLOWING SPECIFICATIONS ARE INTENDED TO DESCRIBE EQUIPMENT FOR A SEMIAUTOMATIC REFUSE COLLECTION SYSTEM WHICH WILL UTILIZE HEAVY DUTY EIGHTY OR NINETY GALLON RESIDENTIAL CARTS AND HYDRAULIC LIFTING MECHANISMS (DUMPERS) INSTALLED ON REAR LOADING PACKER BODIES FOR DUMPING THESE CARTS.

1. THE DUMPER SHALL CONSIST OF A STATIC SUB-FRAME ATTACHED TO THE TRUCK BODY AND A DYNAMIC LIFTING PLATE (SHELL), PAINTED SAFETY YELLOW.
2. THE LIFTING FRAME SHALL BE ADAPTABLE AND INTERCHANGEABLE FOR EIGHTY OR NINETY GALLON WHEELED CARTS SUCH AS THOSE MANUFACTURED BY WASTEWHEELER, ZARN, TOTER, AMERI-KART, ETC.
3. THE DUMPER SHALL HAVE A COMPLETE CYCLE TIME OF 8 TO 10 SECONDS.
4. THE LIFTING FRAME IS CONTROLLED BY A THREE-POSITION, FOUR-WAY DIRECTIONAL CONTROL VALVE WITH A RATED CAPACITY OF 20 GALLONS PER MINUTE.
5. ALL HYDRAULIC LINES SHALL MEET OR EXCEED REQUIREMENTS OF SAE 100R2 2-WIRE BRAID HYDRAULIC HOSE WITH A MAXIMUM WORKING PRESSURE OF 3500 PSI.
6. THE LIFTING PLATE (DUMPER SHELL) SHALL BE CONSTRUCTED OF 3/8" STEEL PLATE AND MUST BE EASILY REPLACEABLE IF DAMAGED (ATTACHED TO THE STATIC FRAME USING GRADE 8 BOLTS).
7. ALL MAIN PIVOT RODS SHALL BE 1 1/4" DIAMETER COLD ROLLED STEEL
8. THE MAIN PIVOT SHAFT WILL BE EQUIPPED WITH CAST IRON BUSHINGS AND HAVE SCREW IN GREASE FITTINGS .
9. THE LOWER LOCKING CATCH ON THE LIFTING FRAME IS MECHANICALLY OPERATED SO THAT IT SECURELY LATCHES ONTO THE LOWER BAR OF THE CART AS IT IS BEING LIFTED. THE CATCH MUST THEN BE CAPABLE OF HOLDING THE CART FIRMLY IN PLACE IN THE INVERTED POSITION, EVEN IF THE CART IS SHAKEN TO REMOVE ALL REFUSE FROM WITHIN. BEING MECHANICALLY OPERATED, THE LATCH MUST THEN RELEASE THE CART AS IT IS LOWERED. THE LATCH MECHANISM MUST BE BOLTED TO THE SHELL FOR EASE OF REPLACEMENT IF DAMAGED.
10. THE LIFTING FRAME IS POWERED BY A HELICAL ROTARY ACTUATOR RATED FOR A MINIMUM OF 180 DEGREES ROTATION AND 3000 PSI OPERATING PRESSURE.
11. THE STATIC FRAME WILL BE ATTACHED TO THE TRUCK BY MEANS OF A BOLT ON KIT. THE BOLT ON KIT ASSURES MINIMUM DOWN TIME FOR THE TRUCK REGARDLESS OF DAMAGE TO THE DUMPER.



1310 Miller Road
Greenville, SC 296078

Barker Products

Lift Unit Specialist

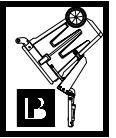

Phone:864-288-7384
Fax:864-297-1292

BPH SERIES LIFT UNIT WARRANTY

Barker Products warranties each new dump unit to be free of defects in material and workmanship under normal use and service for a period of 1 year or 2000 hours of operation, whichever comes first, from the date of delivery.

This warranty excludes any obligations by BARKER PRODUCTS for the cost of down time. BARKER PRODUCTS will not warranty any dump unit which has been subject to misuse, neglect, alteration, or damaged by an accident.

On any work not performed by BARKER PRODUCTS or it's representative, the customer will be responsible for freight charges on all parts shipped under warranty. Parts will be invoiced at time of shipment. Defective parts must be returned to BARKER PRODUCTS within 30 days. If the part is determined to be defective the customer will be credited for the original invoice.

Customer warranty labor charges must be approved by BARKER PRODUCTS in advance. If not contacted for approval, BARKER PRODUCTS will not be liable for the warranty labor charge.



BP LIFTS
By Barker Products
1310 Miller Road, Greenville, SC 29607 Phone:800-349-3149

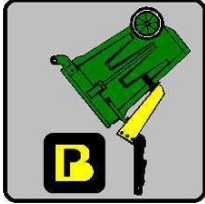

BPH-15 Envelope Dimensions

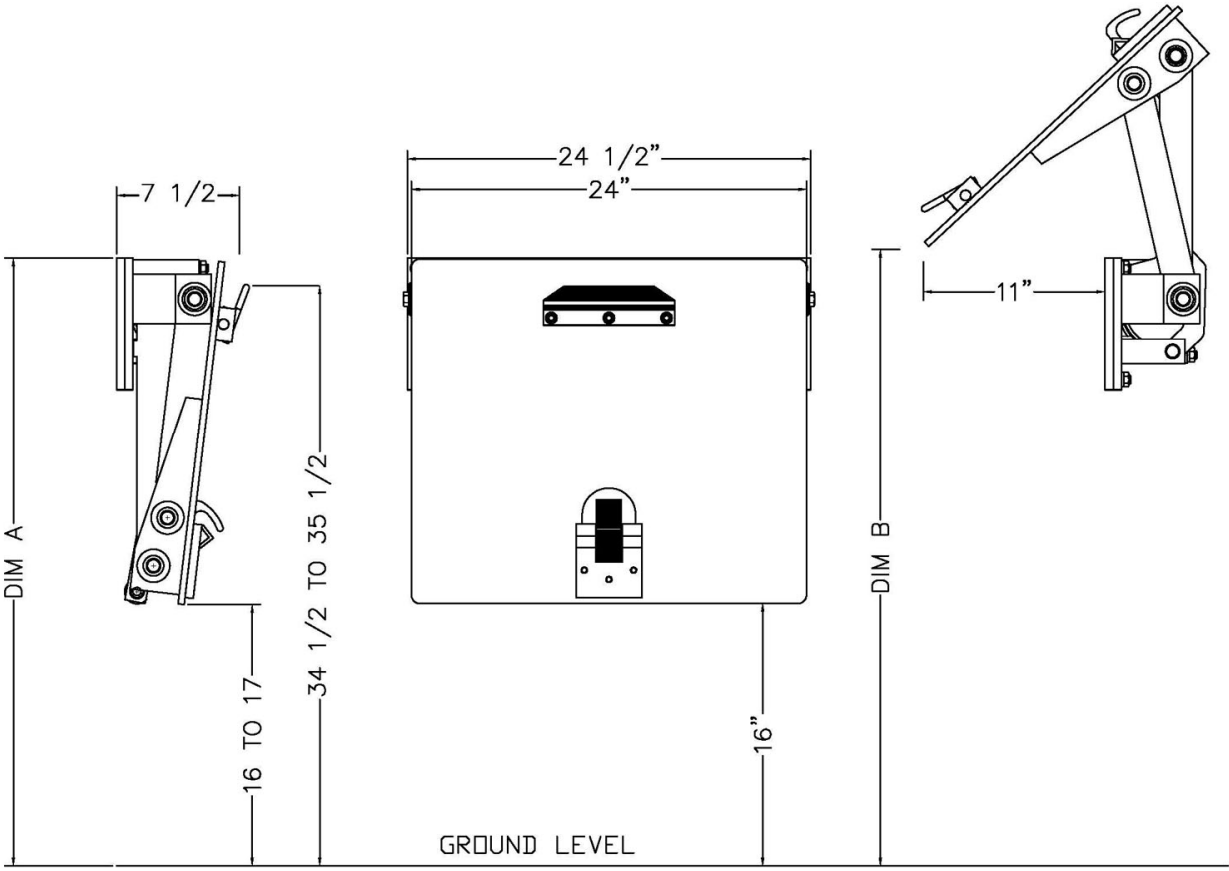

Model	Dim A	Dim B
BPH-1516	36" to 37"	37" to 39"
BPH-1518	38" to 39"	41" to 43"
BPH-1520	40" to 41"	45" to 47"
BPH-1522	42" to 43"	49" to 51"
BPH-1524	44" to 45"	53" to 55"
BPH-1526	46" to 47"	57" to 59"
BPH-1528	48" to 49"	61" to 63"

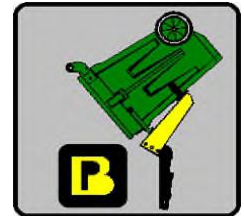
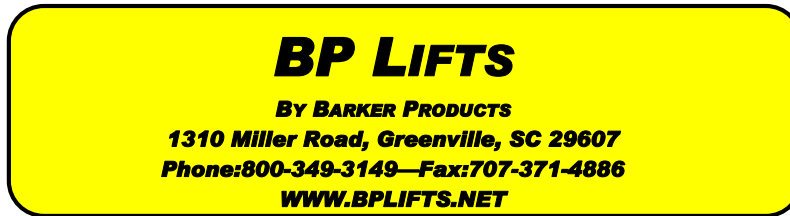

Lift Unit Installation

1. Truck must be empty, clean and parked on a level surface before installation is started.
2. Remove all bumpers and running boards that will interfere with the location of the lift units. Relocate lower mounted tail lights as needed.
3. Measure and mark the centerline of the truck hopper. The centerline of the unit or units should be a minimum of 17" from the hopper centerline.
4. Hand valves should be mounted on the side of the hopper at the most convenient height for the operator and clear of the packer controls.
5. The top of the unit mounting plate should be tack welded in place at the height recommended on the envelope dimension sheet of the unit.
CAUTION: SEE NOTE BELOW PICTURE
6. All dimensions should be approved by the customer before final welding.
7. If the mounting plate extends more than 2" above the hopper, a brace should be added.

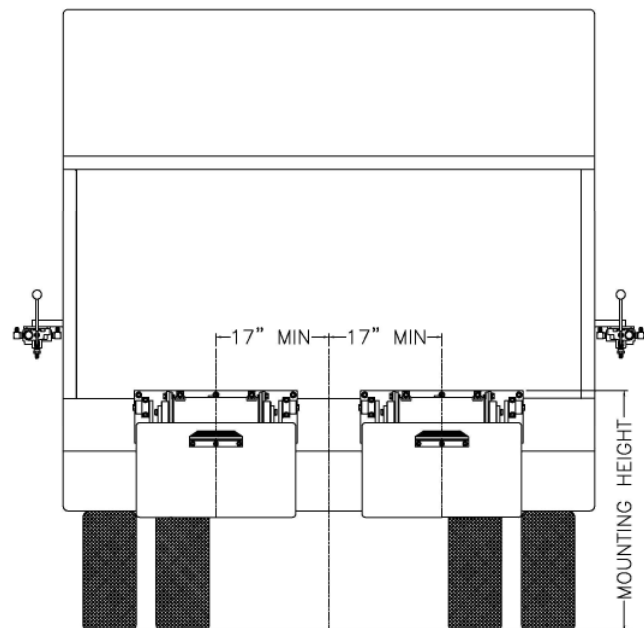

Mounting heights and locations are recommendations only. It is the responsibility of the installer to insure that the customer is satisfied with the height. Barker Products recommends that after the units are tacked in place, try the units with the can or cans the customer uses. The customer should approve your mount before final welding.

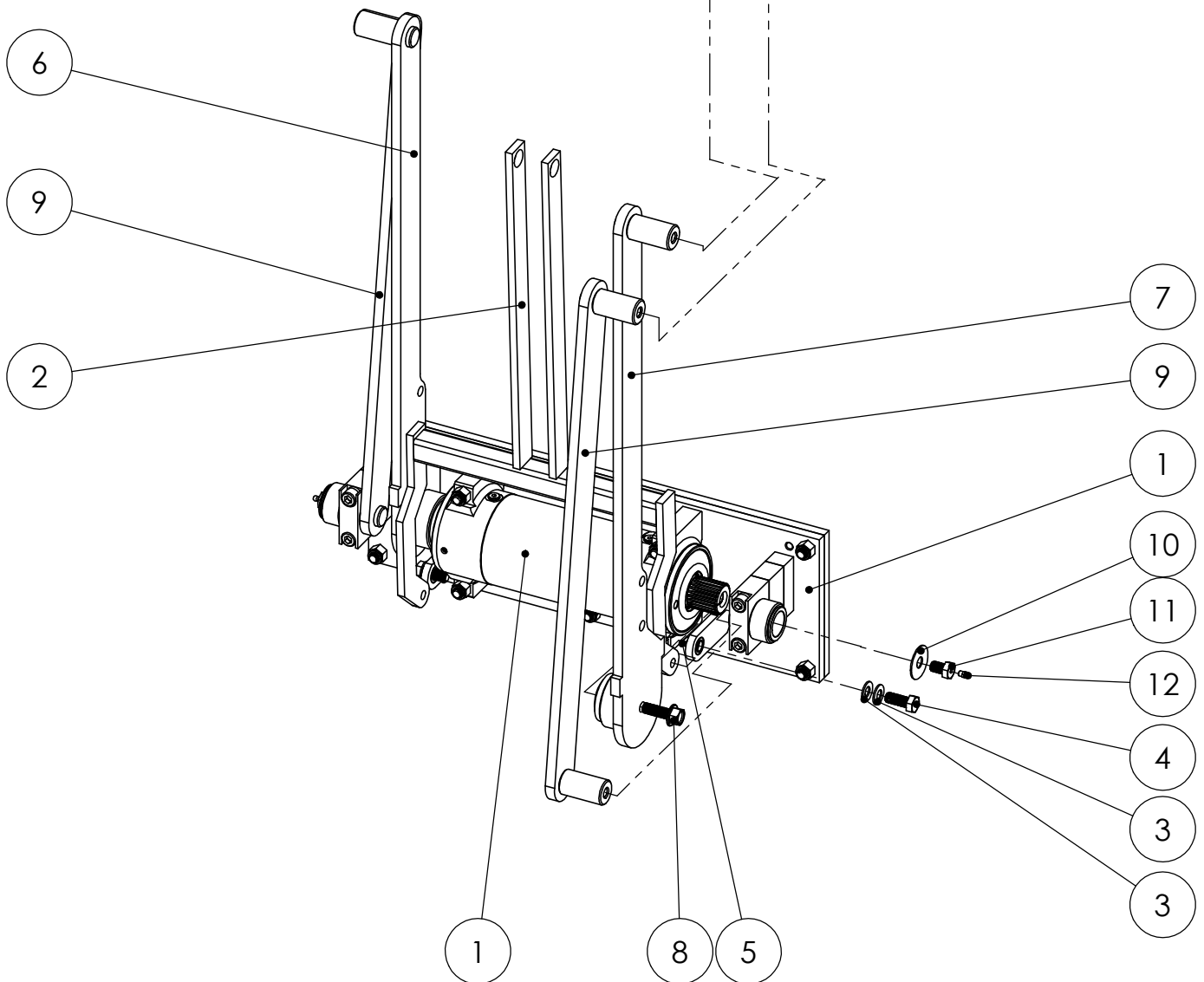
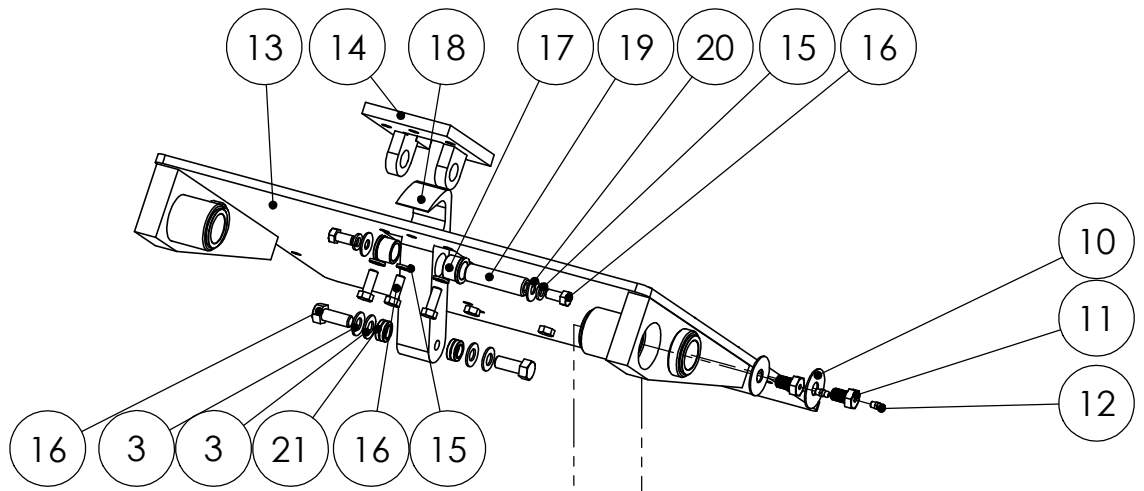

DO NOT SCALE DRAWING		BPH-1528 LIFT UNIT	
UNLESS OTHERWISE SPECIFIED: DIMENSIONS ARE IN INCHES TOLERANCES: FRACTIONAL $\pm 1/32$ ANGULAR: MACH $\pm 1^\circ$ BEND $\pm 1^\circ$ TWO PLACE DECIMAL ± 0.010 THREE PLACE DECIMAL ± 0.005		DRAWING NO BU09600 PARTS	REV 00
MATERIAL: NOTED	SCALE: 1:8	WEIGHT: 242.160 #	SHEET 1 OF 2



BARKER PRODUCTS
1310 MILLER ROAD
GREENVILLE, SC
29607

DRAWN BY: R WYMAN
DATE: 11/27/2018
MATERIAL: NOTED

ITEM NO.	PART NUMBER	DESCRIPTION	QTY.
1	BWA09010	H MAINFRAME SUB ASSY	1
2	BW09560	HOOK LINK BPH-1528	1
3	BW02100	1/2" BELLEVILLE SPRING WASHER	8
4	BW02140	1/2-13 X 1 1/4 LOCK BOLT	2
5	BW02125	5/32 X 3/4 SPRING PIN	2
6	BW11360	LEFT LIFT ARM BPH-1528	1
7	BW11365	RIGHT LIFT ARM BPH-1528	1
8	XAE081312	1/2-13 X 1 1/2 FLANGED HHCS	2
9	BW09460	GUIDE ARM BPH-1528	2
10	BW07115	BEARING CAP WASHER	6
11	BW07110	BEARING CAP BOLT	6
12	BW01110	GREASE FITTING - 1/4-28 SHORT	6
13	BWA09020	LIFT PLATE SUB ASSY	1
14	BW00815	HOOK MOUNT	1
15	XEB061000	3/8" LOCK WASHER	5
16	XAA081310	1/2-13 X 1 1/4 HHCS	7
17	BW00940	HOOK BEARING	2
18	BW09040	HOOK	1
19	BW00830	HOOK SHAFT	1
20	XEA061000	3/8 FLAT WASHER	2
21	BW99308	1/2" SPHERICAL BEARING	2



BARKER PRODUCTS
1310 MILLER ROAD
GREENVILLE, SC
29607

DRAWN BY: R WYMAN
DATE: 11/27/2018
MATERIAL: NOTED

DO NOT SCALE
DRAWING
UNLESS OTHERWISE SPECIFIED:
DIMENSIONS ARE IN INCHES
TOLERANCES:
FRACTIONAL ±1/32
ANGULAR: MACH ±1° BEND ±1°
TWO PLACE DECIMAL ±0.010
THREE PLACE DECIMAL ±0.005

BPH-1528 LIFT UNIT

DRAWING NO
BU09600 PARTS

REV
00

SCALE: 1:8 WEIGHT: 242.160 # SHEET 2 OF 2

ITEM NO.	PART NUMBER	DESCRIPTION	QTY.
1	BW09010	MAINFRAME - H-15	1
2	BZ09016	GUIDE ARM SPACER 1 1/2	2
3	BW10080	TOP BEARING	2
4	XEC0806080	1/2" HIGH COLLAR LOCK WASHER	4
5	XAB082028	1/2-20 X 3 1/2 SHCS	4
6	BW00934	CAST FLANGE BUSHING	4
7	BW99308	1/2" SPHERICAL BEARING	2
8	BW07030	MOUNT PLATE H	1
9	BW07140	PLATE STUD	6
10	XDC082000	1/2-20 NYLOK NUT	10
11	BW07125	ACTUATOR MOUNT STUD	4
12	BW07000	15K ACTUATOR	1
13	BW07001	O-RING GREASE SEAL	2
14	BV00055	093 X 6T4S45 ORIFICE FITTING	1
15	BR05285	6802-06-04-NWO	1

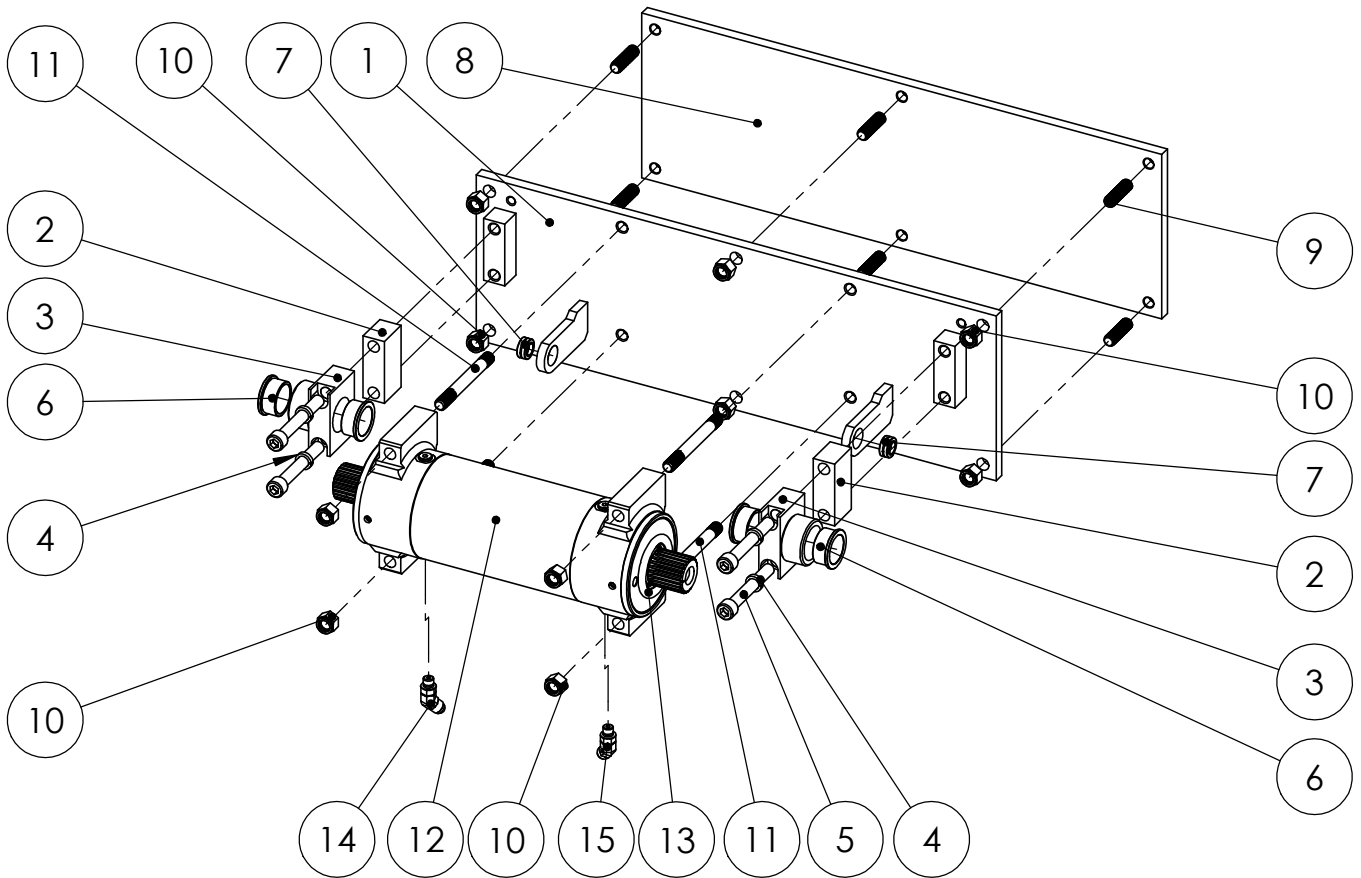

DO NOT SCALE DRAWING		H MAINFRAME SUB ASSY	
UNLESS OTHERWISE SPECIFIED: DIMENSIONS ARE IN INCHES TOLERANCES: FRACTIONAL ±1/32 ANGULAR: MACH ±1° BEND ±1° TWO PLACE DECIMAL ±0.010 THREE PLACE DECIMAL ±0.005		DRAWING NO	REV
		BWA09010 PARTS	00
SCALE: 1:8		WEIGHT: 113.993 #	SHEET 1 OF 1



BARKER PRODUCTS
1310 MILLER ROAD
GREENVILLE, SC
29607

DRAWN BY: R WYMAN
DATE: 11/21/2018
MATERIAL: NOTED

ITEM NO.	PART NUMBER	DESCRIPTION	EXPLODED PARTS VIEW/QTY.
1	BW09020	LIFT PLATE - H	1
2	BW00800	SADDLE	1
3	XAA061610	3/8-16 X 1 1/4 HHCS	3
4	XDC061600	3/8-16 NYLOK NUT	3
5	BW10040	RIGHT LP MOUNT	1
6	BW10030	LEFT LP MOUNT	1
7	XAC081308	1/2-13 X 1 BHCS	6
8	BW00934	CAST FLANGE BUSHING	8

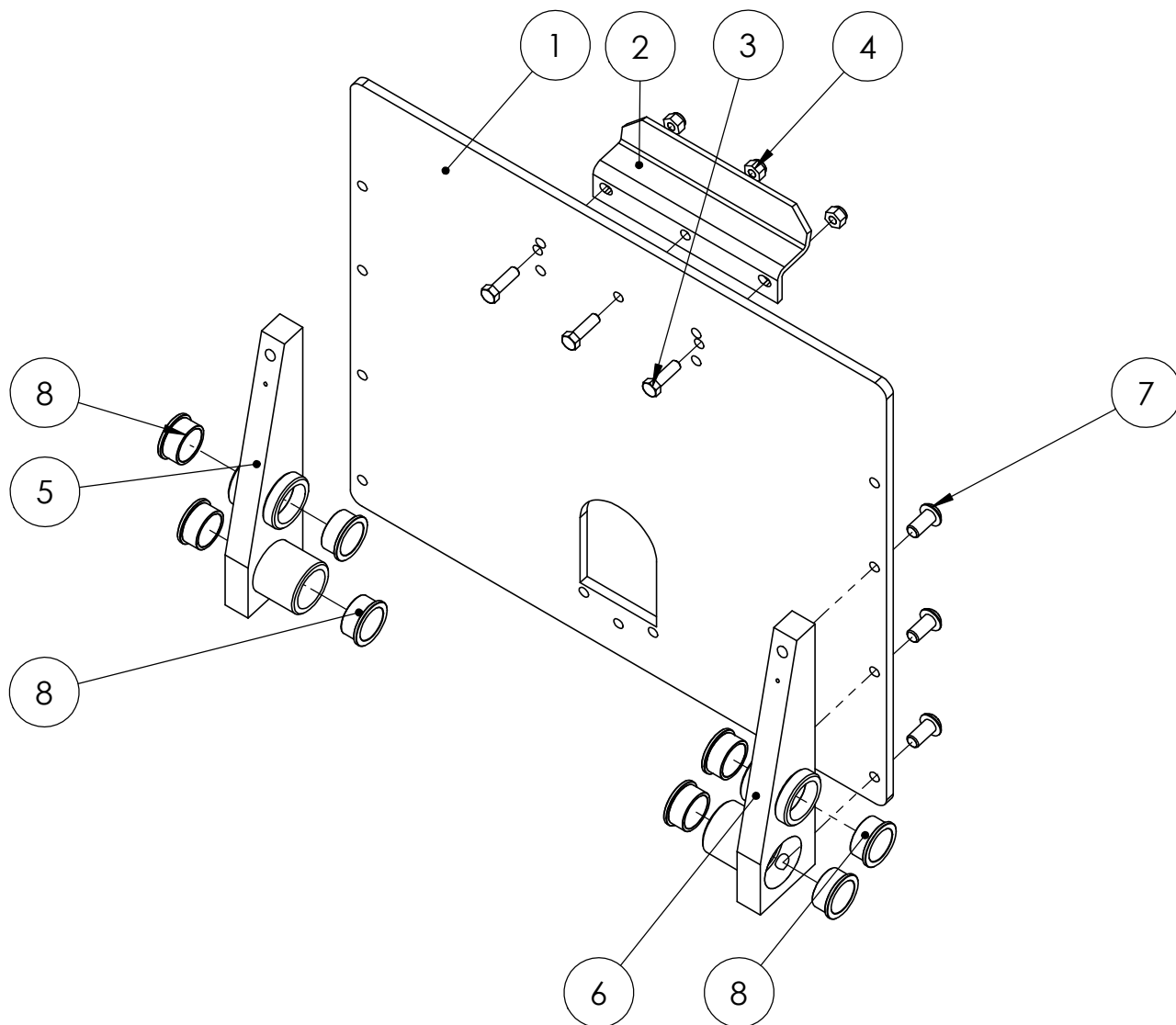

DO NOT SCALE DRAWING		LIFT PLATE SUB ASSY	
UNLESS OTHERWISE SPECIFIED: DIMENSIONS ARE IN INCHES		DRAWING NO	
TOLERANCES:		BWA09020 PARTS	
FRACTIONAL ±1/32		SCALE: 1:6	REV 00
ANGULAR: MACH ±1° BEND ±1°		WEIGHT: 67.134 #	SHEET 1 OF 1
TWO PLACE DECIMAL ±0.010			
THREE PLACE DECIMAL ±0.005			



BARKER PRODUCTS
1310 MILLER ROAD
GREENVILLE, SC
29607

DRAWN BY: R WYMAN
DATE: 8/10/2017
MATERIAL: NOTED