



BP LIFTS

BY BARKER PRODUCTS
1310 Miller Road, Greenville, SC 29607
Phone:800-349-3149—Fax:864-297-1292



Model BPH2-15 Series Lifts



- **Meets ANSI Z245 Type B Specifications**
- **Powered By The Dependable Smooth Acting Helical Rotary Actuator**
- **Splined Shafts To Eliminate Arm Movement And Wear**
- **EZ Bolt On Kit Standard**
- **Heavy Duty Cast Iron Bushings For Long Lift Cycle**
- **37" To 45" Mounting Heights Available**
- **16" Ground Clearance**



BP LIFTS
By Barker Products
1310 Miller Road, Greenville, SC 29607 Phone:800-349-3149



BPH2-1541 Envelope Dimensions

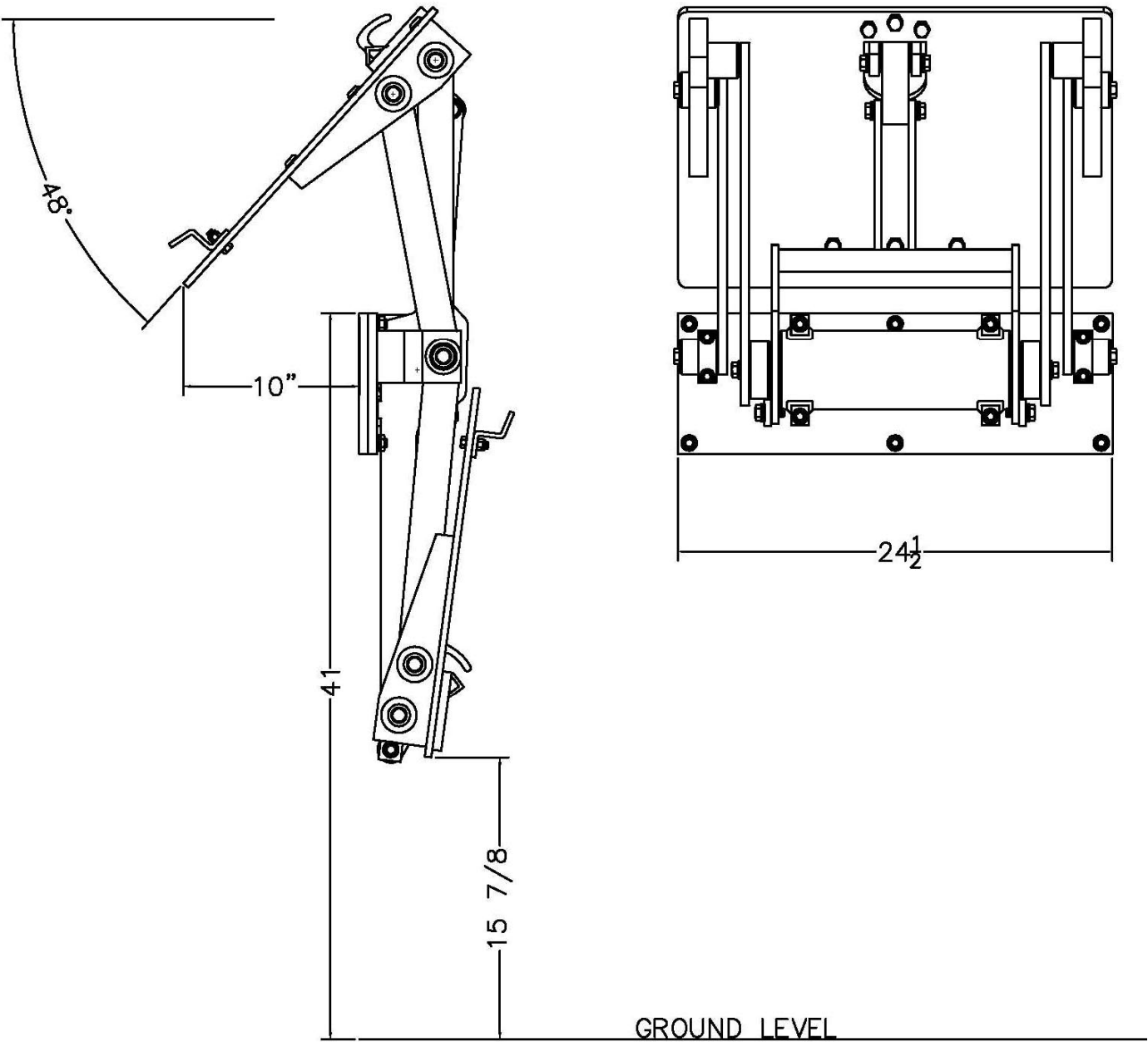

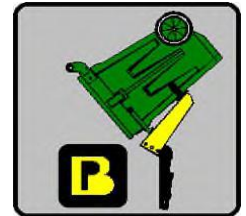
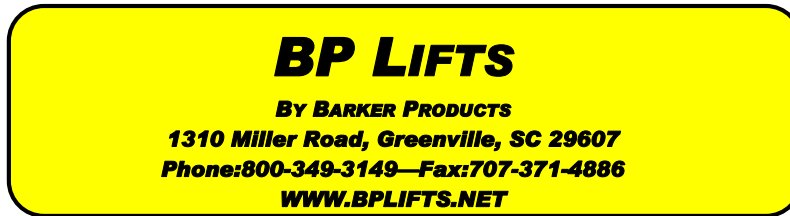

Lift Unit Installation

1. Truck must be empty, clean and parked on a level surface before installation is started.
2. Remove all bumpers and running boards that will interfere with the location of the lift units. Relocate lower mounted tail lights as needed.
3. Measure and mark the centerline of the truck hopper. The centerline of the unit or units should be a minimum of 17" from the hopper centerline.
4. Hand valves should be mounted on the side of the hopper at the most convenient height for the operator and clear of the packer controls.
5. The top of the unit mounting plate should be tack welded in place at the height recommended on the envelope dimension sheet of the unit.
CAUTION: SEE NOTE BELOW PICTURE
6. All dimensions should be approved by the customer before final welding.
7. If the mounting plate extends more than 2" above the hopper, a brace should be added.

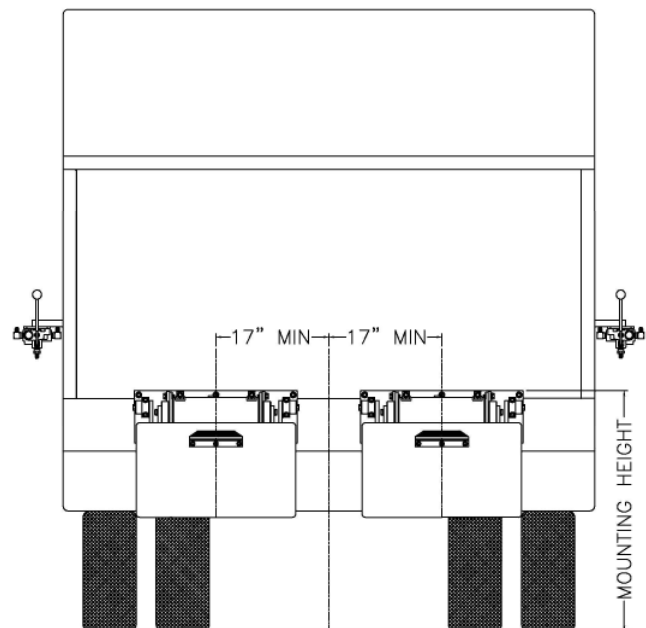

Mounting heights and locations are recommendations only. It is the responsibility of the installer to insure that the customer is satisfied with the height. Barker Products recommends that after the units are tacked in place, try the units with the can or cans the customer uses. The customer should approve your mount before final welding.

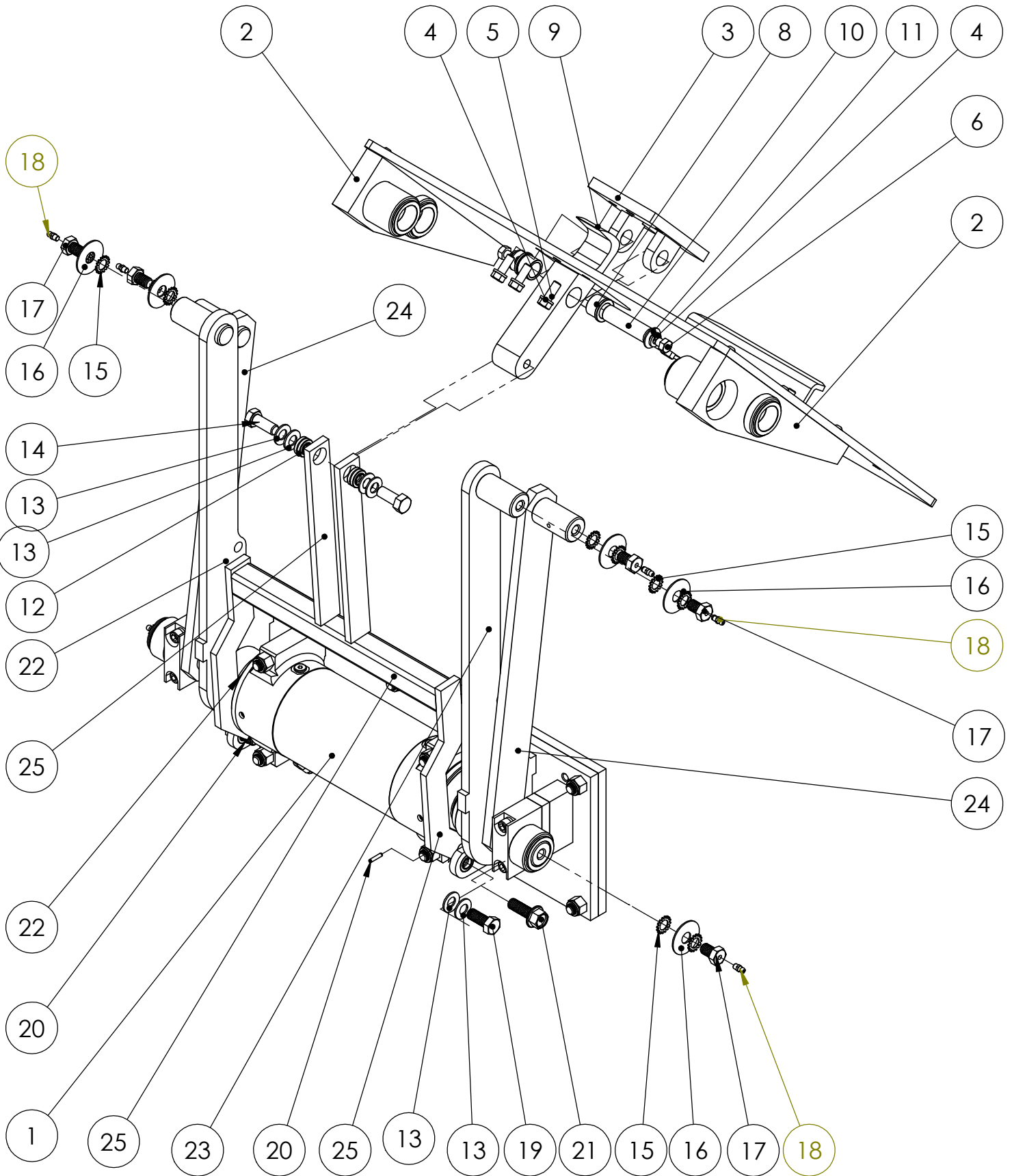

BARKER PRODUCTS
 1310 MILLER ROAD
 GREENVILLE, SC
 29607

DRAWN BY: R WYMAN
 DATE: 1/11/2019
 MATERIAL: NOTED

DO NOT SCALE
 DRAWING
 UNLESS OTHERWISE SPECIFIED:
 DIMENSIONS ARE IN INCHES
 TOLERANCES:
 FRACTIONAL $\pm 1/32$
 ANGULAR: MACH $\pm 1^\circ$ BEND $\pm 1^\circ$
 TWO PLACE DECIMAL ± 0.010
 THREE PLACE DECIMAL ± 0.005

BPH2-1541 LIFT PARTS

DRAWING NO
 BU09741 PARTS

REV
 00

SCALE: 1:6

WEIGHT: 230.285 # SHEET 1 OF 2

ITEM NO.	PART NUMBER	DESCRIPTION	EXPLODED PARTS/QTY.
1	BWA09070	MAINFRAME SUB ASSY	1
2	BWA09020	LIFT PLATE SUB ASSY	1
3	BW00815	HOOK MOUNT	1
4	XEB061000	3/8" LOCK WASHER	5
5	XAA061608	3/8-16 X 1 HHCS	3
6	XAA061606	3/8-16 X 3/4 HHCS	2
7	XAA081310	1/2-13 X 1 1/4 HHCS	1
8	BW00940	HOOK BEARING	2
9	BW09040	HOOK	1
10	BW00830	HOOK SHAFT	1
11	XEA061000	3/8 FLAT WASHER	2
12	BW99308	1/2" SPHERICAL BEARING	2
13	BW02100	1/2" BELLEVILLE SPRING WASHER	8
14	XAA081310	1/2-13 X 1 1/4 HHCS	1
15	BW02150	1/2" EXTERNAL TOOTH LOCK WASHER	12
16	BW07115	BEARING CAP WASHER	6
17	BW07110	BEARING CAP BOLT	6
18	BW01110	1/4-28 GREASE FITTING SHORT	6
19	BW02140	1/2-13 X 1 1/4 LOCK BOLT	2
20	BW02125	5/32 X 3/4 SPRING PIN	2
21	XAE081312	1/2-13 X 1 1/2 FLANGED HHCS	2
22	BW11320	LEFT LIFT ARM	1
23	BW11325	RIGHT LIFT ARM	1
24	BW09741	GUIDE ARM	2
25	BW09520	HOOK LINK	1



BARKER PRODUCTS
1310 MILLER ROAD
GREENVILLE, SC
29607

DRAWN BY: R WYMAN
DATE: 1/11/2019
MATERIAL: NOTED

DO NOT SCALE
DRAWING
UNLESS OTHERWISE SPECIFIED:
DIMENSIONS ARE IN INCHES
TOLERANCES:
FRACTIONAL ±1/32
ANGULAR: MACH ±1° BEND ±1°
TWO PLACE DECIMAL ±0.010
THREE PLACE DECIMAL ±0.005

BPH2-1541 LIFT PARTS

DRAWING NO
BU09741 PARTS

REV
00

SCALE: 1:1 WEIGHT: 230.285 # SHEET 2 OF 2

ITEM NO.	PART NUMBER	DESCRIPTION	MAINFRAME PARTS EXPLODED/QTY.
1	BW09070	MAINFRAME - H2-15	1
2	BZ09014	GUIDE ARM SPACER	2
3	BW99308	1/2" SPHERICAL BEARING	2
4	BW07030	MOUNT PLATE H	1
5	BW07140	PLATE STUD	6
6	XDC082000	1/2-20 NYLOK NUT	10
7	BW07125	ACTUATOR MOUNT STUD	4
8	BW07000	15K ACTUATOR	1
9	BW10080	TOP BEARING	2
10	BW00934	CAST FLANGE BUSHING	4
11	XEC0806080	1/2" HC LOCK WASHER	4
12	XAB082024	1/2-20 X 3 SHCS	4
13	BV00055	093 X 6T4S45 ORIFICE FITTING	1
14	BR05285	6802-06-04-NWO	1
15	BW07001	O-RING GREASE SEAL	2

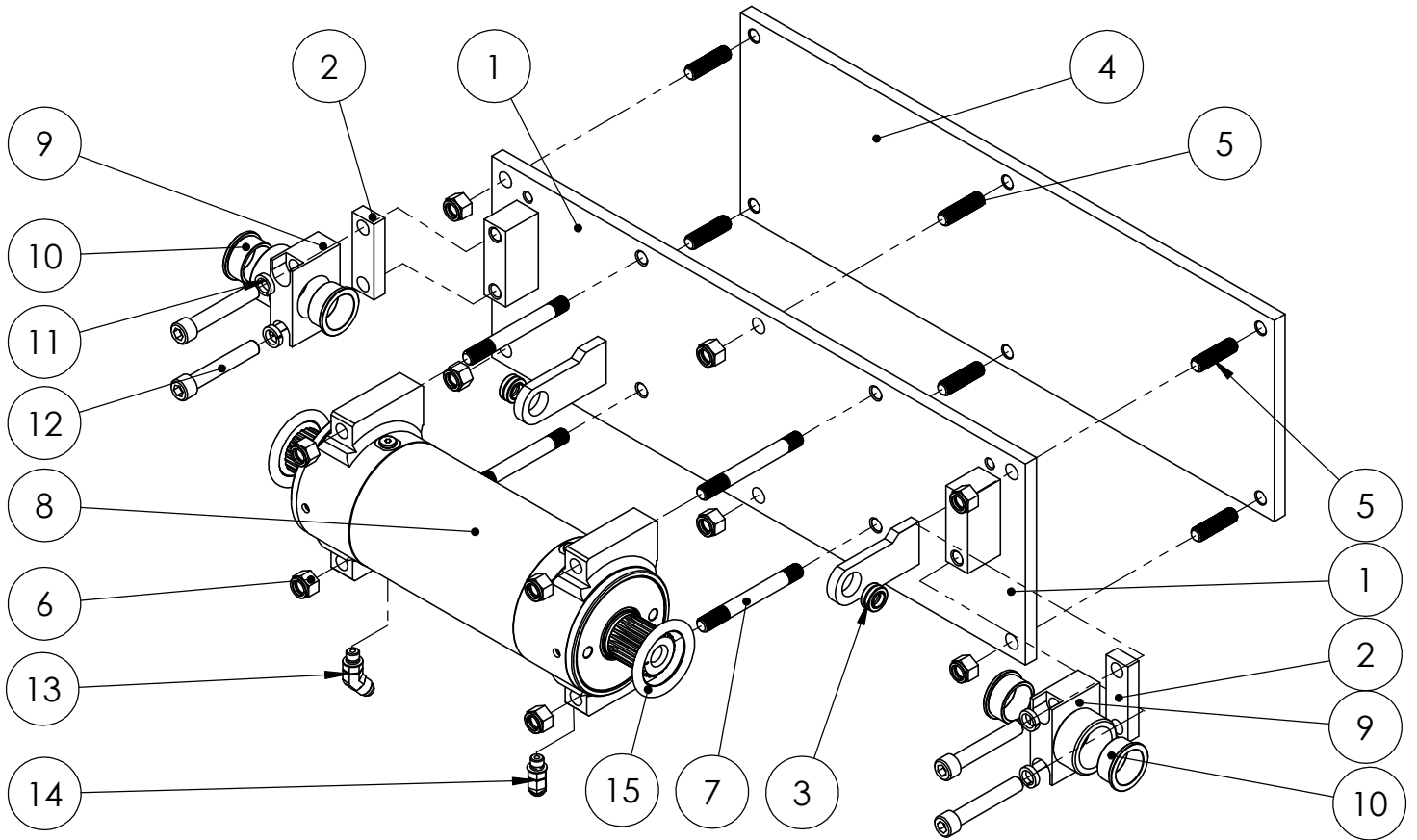

DO NOT SCALE DRAWING		MAINFRAME SUB ASSY H2-15 UNITS	
UNLESS OTHERWISE SPECIFIED: DIMENSIONS ARE IN INCHES TOLERANCES: FRACTIONAL ±1/32 ANGULAR: MACH ±1° BEND ±1° TWO PLACE DECIMAL ±0.010 THREE PLACE DECIMAL ±0.005		DRAWING NO BWA09070	REV 00
SCALE: 1:6		WEIGHT: 113.296 # SHEET 1 OF 1	



BARKER PRODUCTS
1310 MILLER ROAD
GREENVILLE, SC
29607

DRAWN BY: R WYMAN
DATE: 8/10/2017
MATERIAL: NOTED

ITEM NO.	PART NUMBER	DESCRIPTION	EXPLODED PARTS VIEW/QTY.
1	BW09020	LIFT PLATE - H	1
2	BW00800	SADDLE	1
3	XAA061610	3/8-16 X 1 1/4 HHCS	3
4	XDC061600	3/8-16 NYLOK NUT	3
5	BW10040	RIGHT LP MOUNT	1
6	BW10030	LEFT LP MOUNT	1
7	XAC081308	1/2-13 X 1 BHCS	6
8	BW00934	CAST FLANGE BUSHING	8

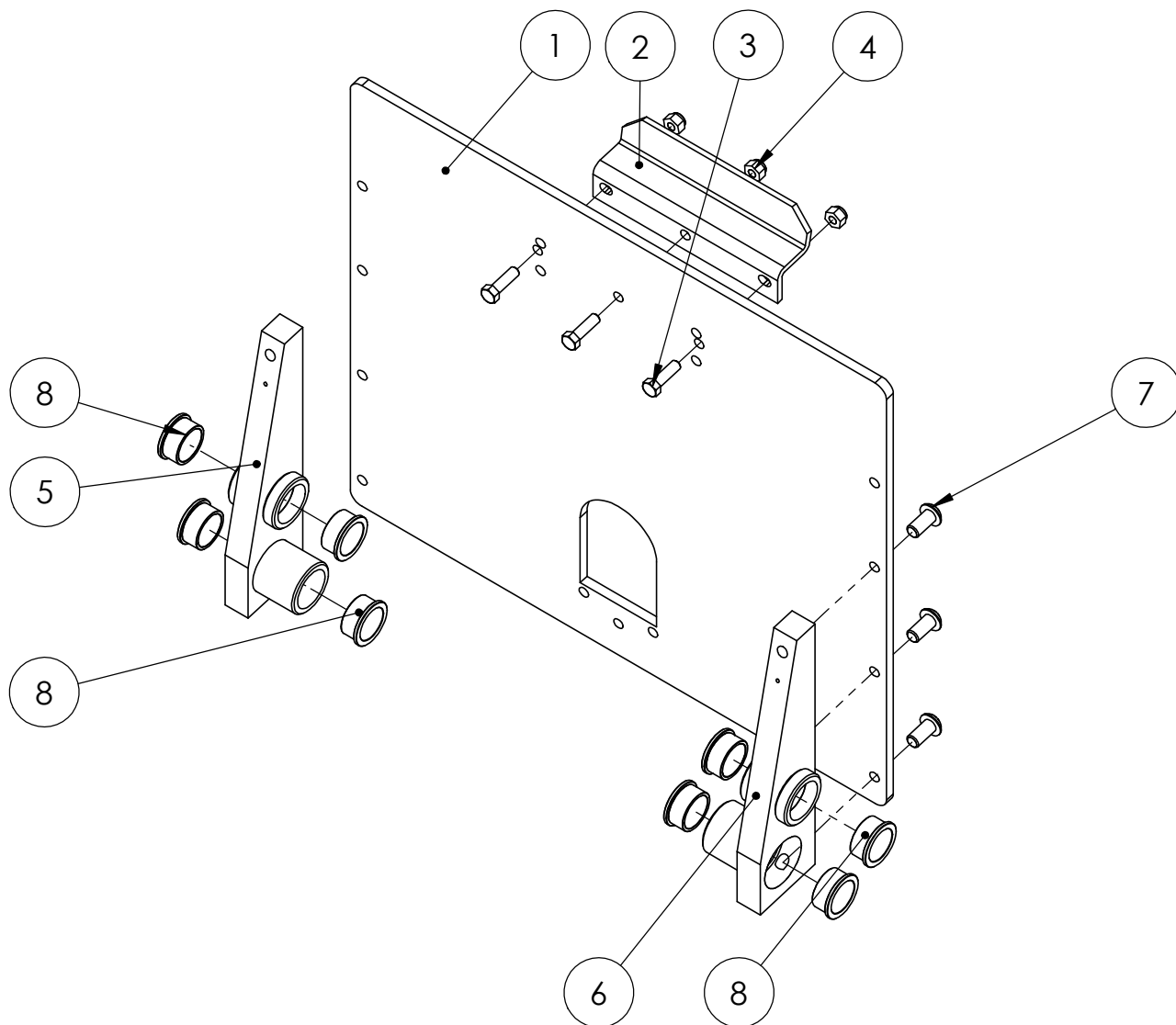

BARKER PRODUCTS
 1310 MILLER ROAD
 GREENVILLE, SC
 29607

DRAWN BY: R WYMAN
 DATE: 8/10/2017
 MATERIAL: NOTED

DO NOT SCALE
 DRAWING
 UNLESS OTHERWISE SPECIFIED:
 DIMENSIONS ARE IN INCHES
 TOLERANCES:
 FRACTIONAL $\pm 1/32$
 ANGULAR: MACH $\pm 1^\circ$ BEND $\pm 1^\circ$
 TWO PLACE DECIMAL ± 0.010
 THREE PLACE DECIMAL ± 0.005

LIFT PLATE SUB ASSY

DRAWING NO
 BWA09020 PARTS

REV
 00

SCALE: 1:6

WEIGHT: 67.134 #

SHEET 1 OF 1



1310 Miller Road
Greenville, SC 296078

Barker Products

Lift Unit Specialist

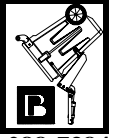

Phone:864-288-7384
Fax:864-297-1292

BPH SERIES LIFT UNIT WARRANTY

Barker Products warranties each new dump unit to be free of defects in material and workmanship under normal use and service for a period of 1 year or 2000 hours of operation, whichever comes first, from the date of delivery.

This warranty excludes any obligations by BARKER PRODUCTS for the cost of down time. BARKER PRODUCTS will not warranty any dump unit which has been subject to misuse, neglect, alteration, or damaged by an accident.

On any work not performed by BARKER PRODUCTS or it's representative, the customer will be responsible for freight charges on all parts shipped under warranty. Parts will be invoiced at time of shipment. Defective parts must be returned to BARKER PRODUCTS within 30 days. If the part is determined to be defective the customer will be credited for the original invoice.

Customer warranty labor charges must be approved by BARKER PRODUCTS in advance. If not contacted for approval, BARKER PRODUCTS will not be liable for the warranty labor charge.