

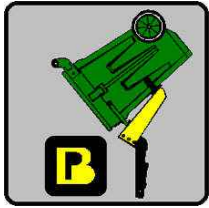

BP LIFTS
BY BARKER PRODUCTS
1310 Miller Road, Greenville, SC 29607
Phone:800-349-3149—Fax:864-297-1292



BPH2-27 SERIES LIFTS



***Powered By A 27K Helical Actuator
With
Splined Shafts To Eliminate Arm Movement & Wear
For
Extreme Heavy Duty High Lift Applications
45" To 57" Mounting Heights
50" To 74" Dump Heights
Over 50 Degree Dump Angle To Empty Can Quickly
Dumps Deep Into Hopper to Prevent Spillage
Hardened Steel Bearings At All Pivot Points***

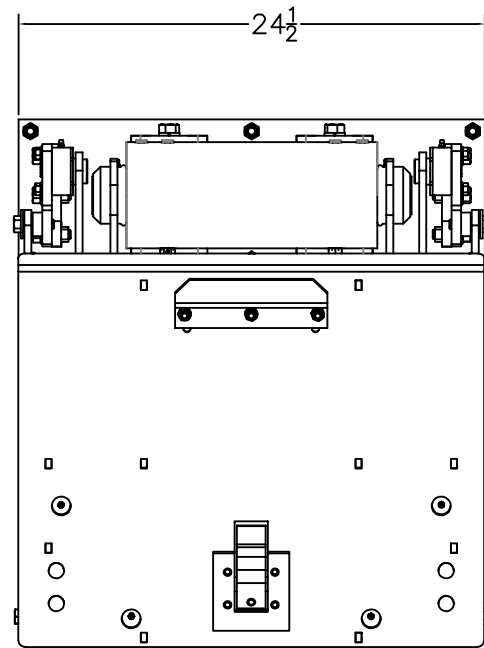
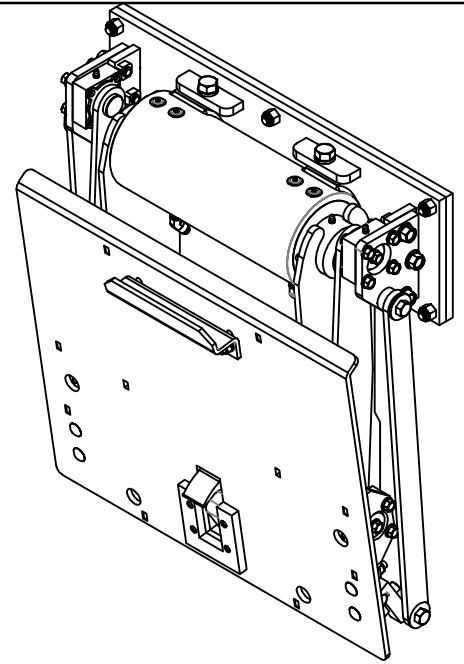
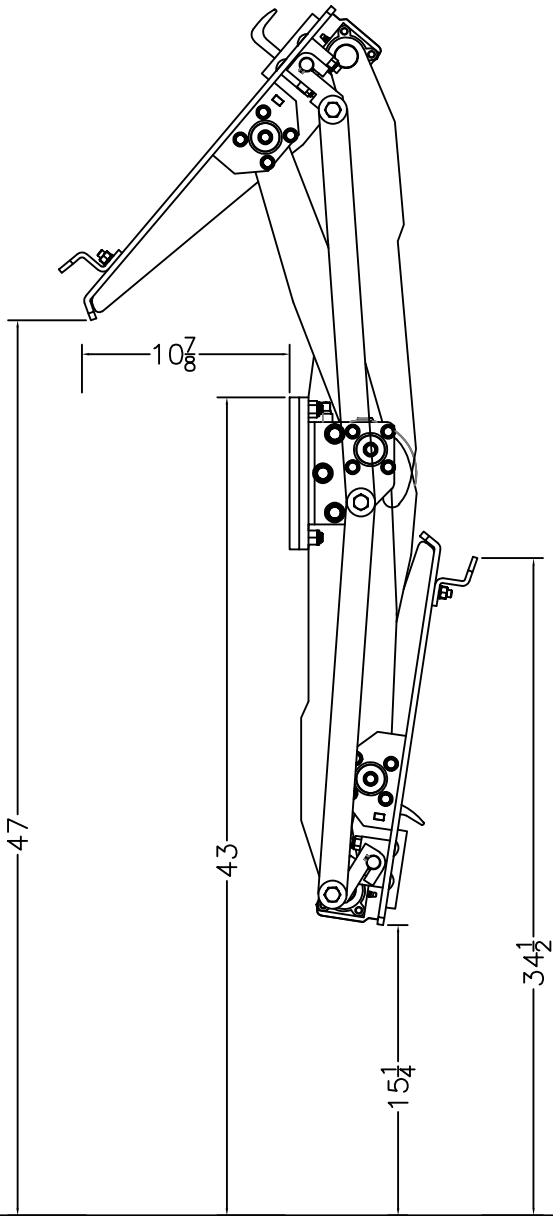

BARKER PRODUCTS
1310 MILLER ROAD
GREENVILLE, SC
29607

DRAWN BY: R WYMAN

DATE: 5/13/2020

MATERIAL: NOTED

DO NOT SCALE
DRAWING
UNLESS OTHERWISE SPECIFIED:
DIMENSIONS ARE IN INCHES
TOLERANCES:
FRACTIONAL ±1/32
ANGULAR: MACH ±1° BEND ±1°
TWO PLACE DECIMAL ±0.010
THREE PLACE DECIMAL ±0.005

BPH2-2743 LIFT UNIT

DRAWING NO
BU18643 ENVELOPE

REV
00

SCALE: 1:10

WEIGHT: 265.598 # SHEET 1 OF 1

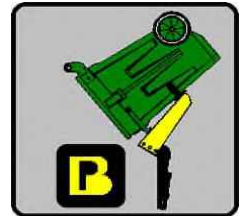
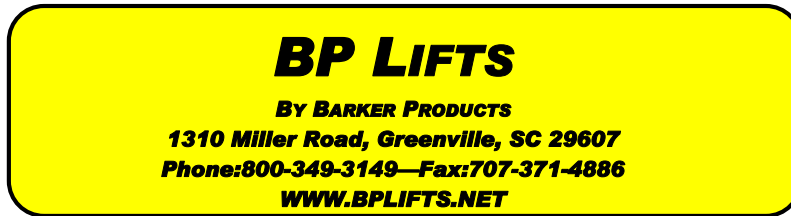

Lift Unit Installation

1. Truck must be empty, clean and parked on a level surface before installation is started.
2. Remove all bumpers and running boards that will interfere with the location of the lift units. Relocate lower mounted tail lights as needed.
3. Measure and mark the centerline of the truck hopper. The centerline of the unit or units should be a minimum of 17" from the hopper centerline.
4. Hand valves should be mounted on the side of the hopper at the most convenient height for the operator and clear of the packer controls.
5. The top of the unit mounting plate should be tack welded in place at the height recommended on the envelope dimension sheet of the unit.
CAUTION: SEE NOTE BELOW PICTURE
6. All dimensions should be approved by the customer before final welding.
7. If the mounting plate extends more than 2" above the hopper, a brace should be added.

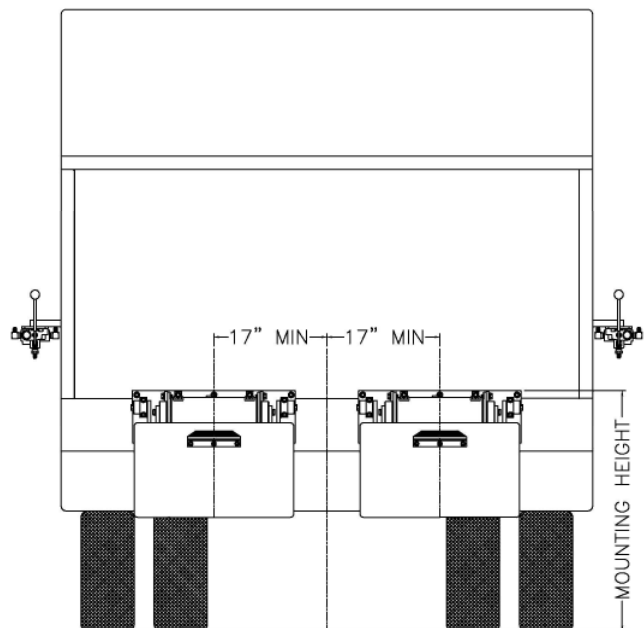

Mounting heights and locations are recommendations only. It is the responsibility of the installer to insure that the customer is satisfied with the height. Barker Products recommends that after the units are tacked in place, try the units with the can or cans the customer uses. The customer should approve your mount before final welding.

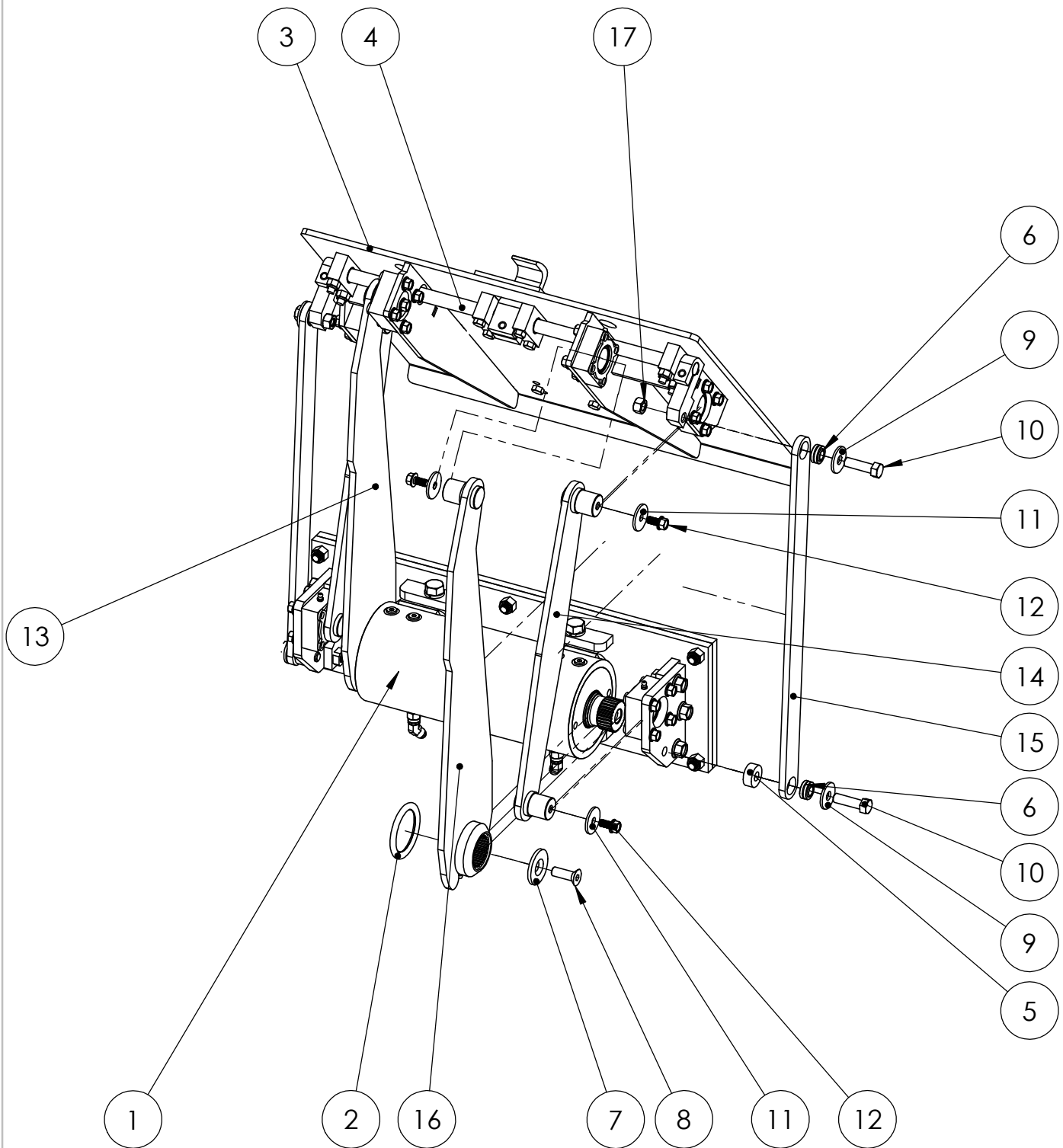

BARKER PRODUCTS
 1310 MILLER ROAD
 GREENVILLE, SC
 29607

DRAWN BY: R WYMAN
 DATE: 5/12/2020
 MATERIAL: NOTED

DO NOT SCALE
 DRAWING
 UNLESS OTHERWISE SPECIFIED:
 DIMENSIONS ARE IN INCHES
 TOLERANCES:
 FRACTIONAL $\pm 1/32$
 ANGULAR: MACH $\pm 1^\circ$ BEND $\pm 1^\circ$
 TWO PLACE DECIMAL ± 0.010
 THREE PLACE DECIMAL ± 0.005

BPH2-2743 LIFT UNIT
 DRAWING NO BU18643
 SCALE: 1:8 WEIGHT: 265.609 # SHEET 1 OF 2
 REV 00

ITEM NO.	PART NUMBER	DESCRIPTION	QTY.
1	BWA18502	MAINFRAME SUB ASSY H2-27XX	1
2	BW18002	O-RING GREASE SEAL	2
3	BWA18540	LIFT PLATE SUB ASSY	1
4	BWA07490	HOOK SUB ASSY	1
5	BW18520	HOOK LINK DRIVE SPACER	2
6	BW99108	1/2" SPHERICAL BEARING	4
7	BW18005	SPLINE CAP HB25	2
8	XAD081312	1/2-13 X 1 1/2 SHCS	4
9	XEA082412SS	FLAT WASHER 1/2 X 1 1/2 X 1/8	4
10	XAA081314	1/2-13 X 1 3/4 HHCS	4
11	XEA062412SS	FLAT WASHER 3/8 X 1 1/2 X 1/8	6
12	XAE061606	3/8-16 X 3/4 FLANGED HHCS	6
13	BW18553	LEFT LIFT ARM	1
14	BW18633	GUIDE ARM	2
15	BW18672	HOOK LINK	2
16	BW18554	RIGHT LIFT ARM	1
17	XDA081300	1/2-13 HEX NUT	2



BARKER PRODUCTS
1310 MILLER ROAD
GREENVILLE, SC
29607

DRAWN BY: R WYMAN
DATE: 5/12/2020
MATERIAL: NOTED

DO NOT SCALE DRAWING		BPH2-2743 LIFT UNIT	
UNLESS OTHERWISE SPECIFIED: DIMENSIONS ARE IN INCHES TOLERANCES: FRACTIONAL ±1/32 ANGULAR: MACH ±1° BEND ±1° TWO PLACE DECIMAL ±0.010 THREE PLACE DECIMAL ±0.005		DRAWING NO BU18643	REV 00
		SCALE: 1:8	WEIGHT: 265.609 # SHEET 2 OF 2

ITEM NO.	PART NUMBER	DESCRIPTION	QTY.
1	BW18505	MAINFRAME T30-27XX	1
2	XEB101000	5/8 LOCKWASHER	4
3	XAE081312	1/2-13 X 1 1/2 FLANGED HHCS	6
4	BW18530	BEARING BODY	2
5	BW21065	PIVOT BEARING SPACER	2
6	BW99320	SPHERICAL BEARING 1 1/4	2
7	XAE061608	3/8-16 X 1 FLANGED HHCS	8
8	BW01110	GREASE FITTING - 1/4-28 SHORT	2
9	BV00025	116 X 1/8 NPT ORIFICE PLUG	2
10	BV00064	6T X 6S ORIFICE FITTING	1
11	BR04842	6502-06-06 MJ-FJS 45 DEG	2
12	BR03830	6400-06-06 M TUBE O-RING	1
13	BW07030	MOUNT PLATE H	1
14	BW07140	PLATE STUD	6
15	XDC082000	1/2-20 NYLOK NUT	6
16	BW18300	ACTUATOR	1
17	BW18503	BEARING MOUNT	2
18	XAB101110	5/8-11 X 1 1/4 SHCS	4

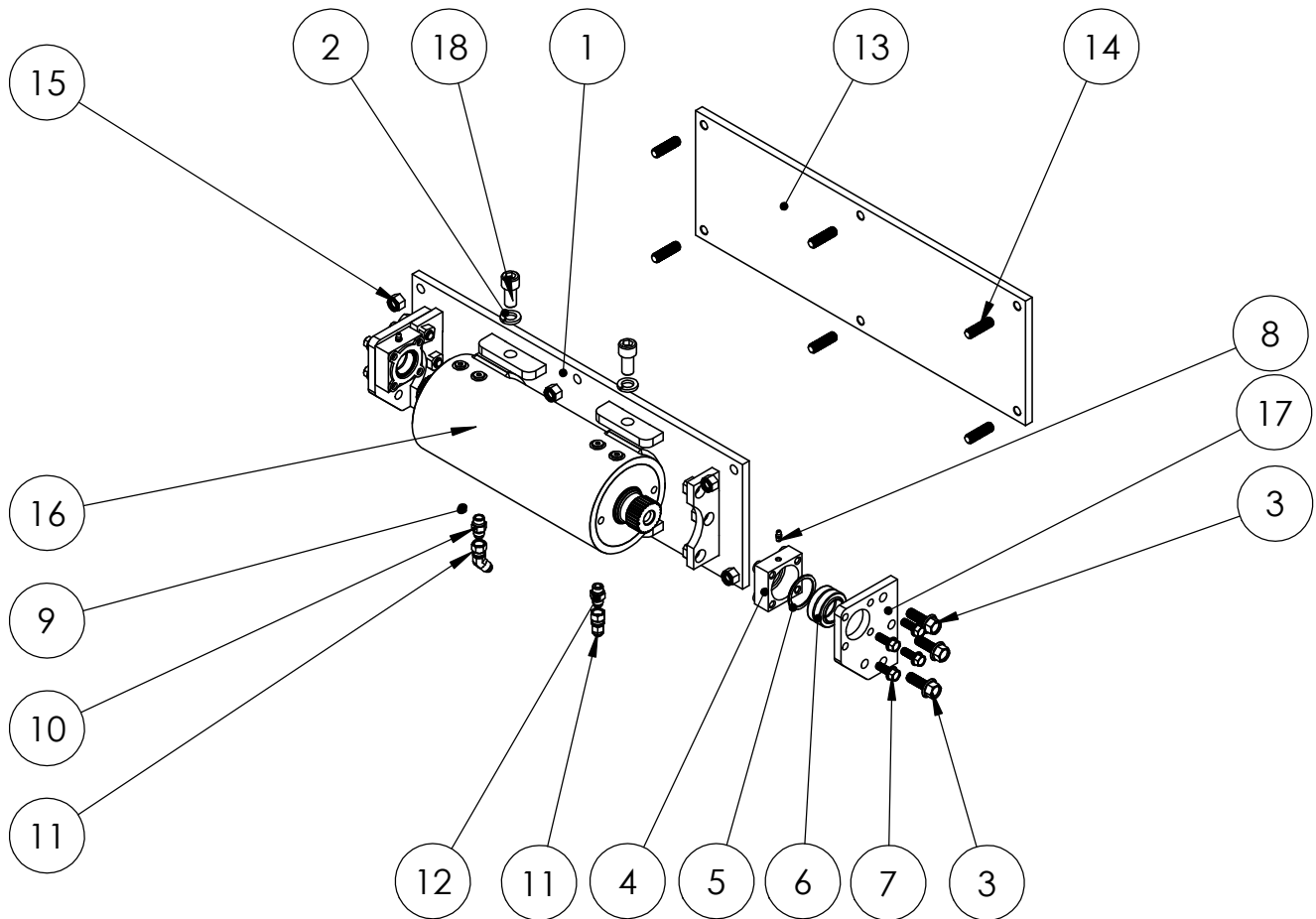

DO NOT SCALE DRAWING		MAINFRAME SUB ASSY H2-2739-41-43	
UNLESS OTHERWISE SPECIFIED: DIMENSIONS ARE IN INCHES		T30-27 ACTUATOR	
TOLERANCES:		DRAWING NO	
FRACTIONAL ±1/32		BWA18502 PARTS	
ANGULAR: MACH ±1° BEND ±1°		REV	
TWO PLACE DECIMAL ±0.010		00	
THREE PLACE DECIMAL ±0.005		SCALE: 1:10	
MATERIAL: NOTED		WEIGHT: 147.601 #	
		SHEET 1 OF 1	



BARKER PRODUCTS
1310 MILLER ROAD
GREENVILLE, SC
29607

DRAWN BY: R WYMAN
DATE: 5/22/2020
MATERIAL: NOTED

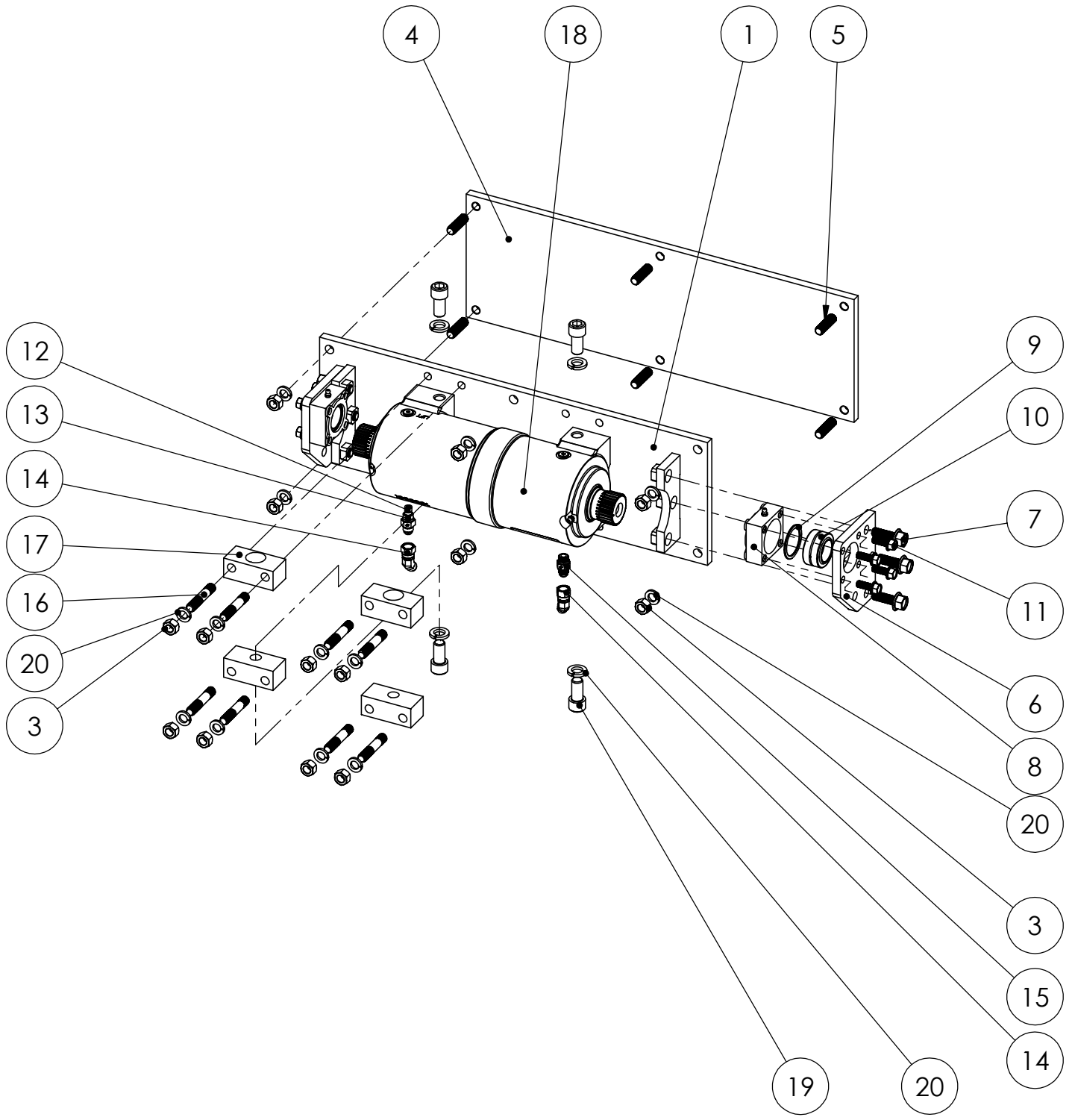

BARKER PRODUCTS
 1310 MILLER ROAD
 GREENVILLE, SC
 29607

DRAWN BY: R WYMAN
 DATE: 4/12/2022
 MATERIAL: NOTED

DO NOT SCALE DRAWING		MAINFRAME SUB ASSY BU186XX	
UNLESS OTHERWISE SPECIFIED: DIMENSIONS ARE IN INCHES TOLERANCES: FRACTIONAL ±1/32 ANGULAR: MACH ±1° BEND ±1° TWO PLACE DECIMAL ±0.010 THREE PLACE DECIMAL ±0.005		DRAWING NO BWA18504 PARTS	REV 00
SCALE: 1:8	WEIGHT: 139.432 #	SHEET 1 OF 2	

ITEM NO.	PART NUMBER	DESCRIPTION	QTY.
1	BW18506	MAINFRAME	1
20	XEB101000	1/2 LOCKWASHER	14
3	XDA082000	1/2-20 HEX NUT	14
4	BW07030	MOUNT PLATE H	1
5	BW07140	PLATE STUD	6
6	BW18503	BEARING MOUNT	2
7	XAE081312	1/2-13 X 1 1/2 FLANGED HHCS	6
8	BW18530	BEARING BODY	2
9	BW21065	PIVOT BEARING SPACER	2
10	BW99320	SPHERICAL BEARING 1 1/4	2
11	XAE061608	3/8-16 X 1 FLANGED HHCS	8
12	BV00025	116 X 1/8 NPT ORIFICE PLUG	2
13	BV00064	6T X 6S ORIFICE FITTING	1
14	BR04842	6502-06-06 MJ-FJS 45 DEG	2
15	BR03830	6400-06-06 M TUBE TO O-RING	1
16	BW07105	ACTUATOR MOUNT STUD	8
17	BW18013	27K ACTUATOR MT BRKT	4
18	BW18300	27K HELICAL ACTUATOR	1
19	XAB101110	5/8-11 X 1 1/4 SHCS	4
20	XEB101000	5/8 LOCK WASHER	4



BARKER PRODUCTS
1310 MILLER ROAD
GREENVILLE, SC
29607

DRAWN BY: R WYMAN
DATE: 4/12/2022
MATERIAL: NOTED

DO NOT SCALE
DRAWING
UNLESS OTHERWISE SPECIFIED:
DIMENSIONS ARE IN INCHES
TOLERANCES:
FRACTIONAL ±1/32
ANGULAR: MACH ±1° BEND ±1°
TWO PLACE DECIMAL ±0.010
THREE PLACE DECIMAL ±0.005

MAINFRAME SUB ASSY
BU186XX

DRAWING NO
BWA18504 PARTS

REV
00

SCALE: 1:8 WEIGHT: 139.432 # SHEET 2 OF 2

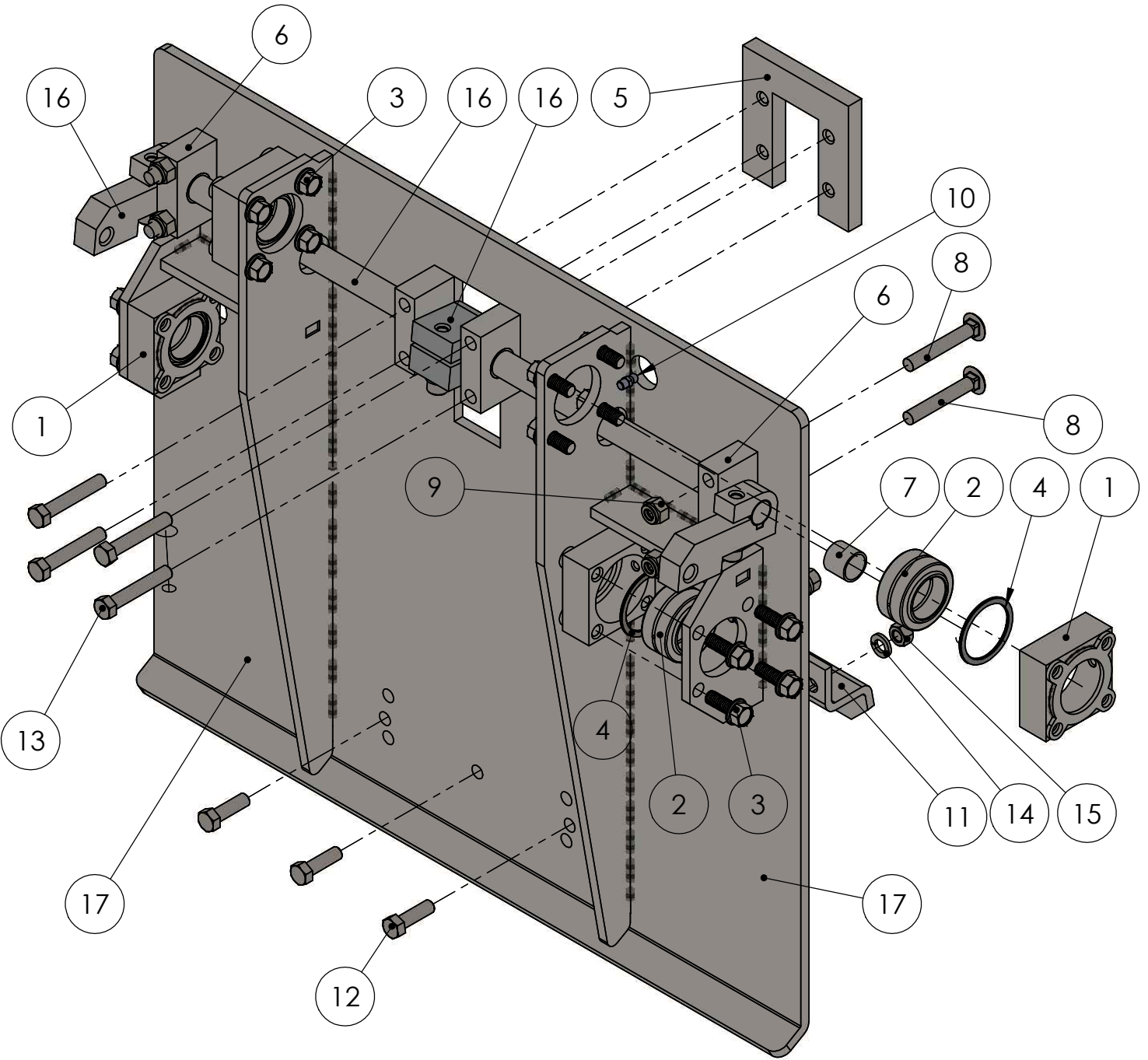

 BARKER PRODUCTS 1310 MILLER ROAD GREENVILLE, SC 29607	DRAWN BY: R WYMAN	DO NOT SCALE DRAWING UNLESS OTHERWISE SPECIFIED: DIMENSIONS ARE IN INCHES TOLERANCES: FRACTIONAL $\pm 1/32$ ANGULAR: MACH $\pm 1^\circ$ BEND $\pm 1^\circ$ TWO PLACE DECIMAL ± 0.010 THREE PLACE DECIMAL ± 0.005	LIFT PLATE SUB ASSY H2-25 LIFTS		REV 01 SHEET 1 OF 2
	DATE: 8/1/2017	DRAWING NO BWA18540	SCALE: 1:4 WEIGHT: 74.297 #		
	MATERIAL: NOTED				

ITEM NO.	PART NUMBER	DESCRIPTION	EXPLODED PARTS/QTY.
1	BW18530	BEARING BODY	4
2	BW99320	SPHERICAL BEARING 1 1/4	4
3	XAE061608	3/8-16 X 1 FLANGED HHCS	16
4	BW21065	PIVOT BEARING SPACER	4
5	BZ03451	SUPPORT PLATE	1
6	BW17130	HOOK BEARING MOUNT	4
7	BW03195	12-DU-12 BEARING	4
8	XAH061620	3/8-16 X 2 1/2 CARRIAGE BOLT	4
9	XDC061600	3/8-16 NYLOK NUT	4
10	BW01110	GREASE FITTING - 1/4-28 SHORT	4
11	BW00800	SADDLE	1
12	XAA061610	3/8-16 X 1 1/4 HHCS	3
13	XAA061618	3/8-16 X 2 1/4 HHCS	4
14	XEB061000	3/8 LOCKWASHER	3
15	XDA061600	3/8-16 HEX NUT	3
16	BWA07490	HOOK SUB ASSY	1
17	BW18540	LIFT PLATE	1



BARKER PRODUCTS
1310 MILLER ROAD
GREENVILLE, SC
29607

DRAWN BY: R WYMAN
DATE: 8/1/2017
MATERIAL: NOTED

DO NOT SCALE
DRAWING
UNLESS OTHERWISE SPECIFIED:
DIMENSIONS ARE IN INCHES
TOLERANCES:
FRACTIONAL ±1/32
ANGULAR: MACH ±1° BEND ±1°
TWO PLACE DECIMAL ±0.010
THREE PLACE DECIMAL ±0.005

LIFT PLATE SUB ASSY
H2-25 LIFTS
DRAWING NO
BWA18540
SCALE: 1:6 WEIGHT: 74.297 # SHEET 2 OF 2
REV
01

ITEM NO.	PART NUMBER	DESCRIPTION	EXPLODED PARTS/QTY.
1	BW18550	HOOK SHAFT	1
2	BW07560	WOODRUFF KEY #806	3
3	BW07490	HOOK	1
4	BW06780	HOOK DRIVE	2
5	XEB061000	3/8 LOCKWASHER	3
6	XAB061612	3/8-16 X 1 1/2 SHCS	3

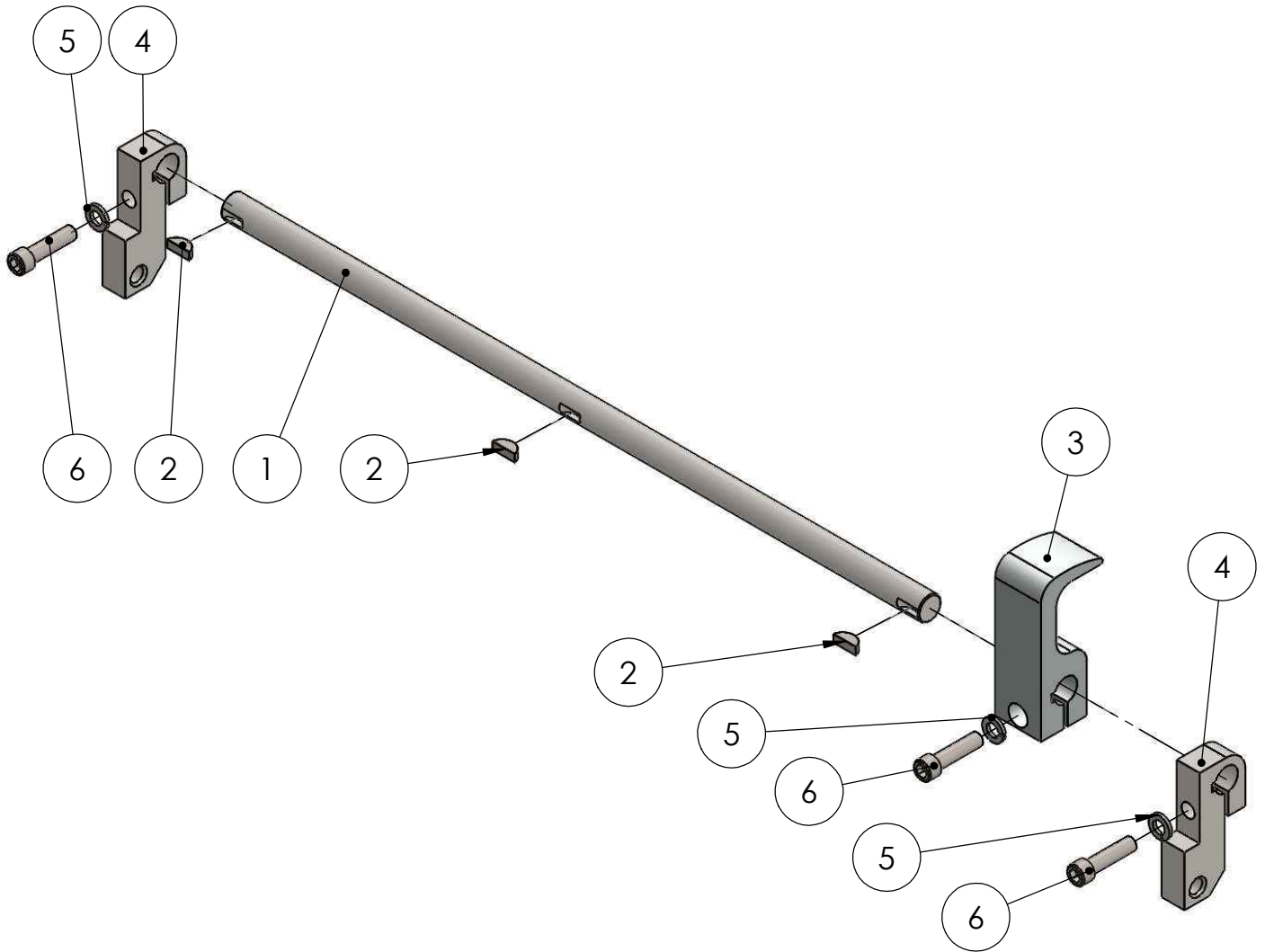

DO NOT SCALE DRAWING		HOOK SUB ASSY H2-25	
UNLESS OTHERWISE SPECIFIED: DIMENSIONS ARE IN INCHES TOLERANCES: FRACTIONAL $\pm 1/32$ ANGULAR: MACH $\pm 1^\circ$ BEND $\pm 1^\circ$ TWO PLACE DECIMAL ± 0.010 THREE PLACE DECIMAL ± 0.005		DRAWING NO BWA07490	REV 00
SCALE: 1:4	WEIGHT: 6.177 #	SHEET 1 OF 1	



BARKER PRODUCTS
1310 MILLER ROAD
GREENVILLE, SC
29607

DRAWN BY: R WYMAN
DATE: 8/1/2017
MATERIAL: NOTED

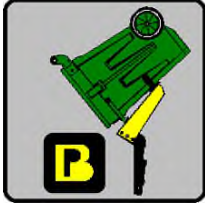
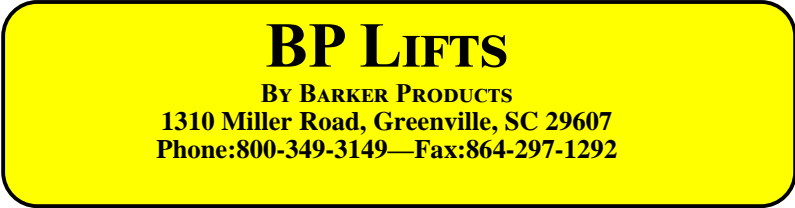

***BPH27-186XX SERIES
LIFT UNIT WARRANTY***

Barker Products warrants each new dump unit to be free of defects in material and workmanship under normal use and service for a period of 1 year or 2000 hours of operation, whichever comes first, from the date of delivery.

This warranty excludes any obligations by BARKER PRODUCTS for the cost of down time. BARKER PRODUCTS will not warranty any dump unit which has been subject to misuse, neglect, alteration, or damaged by an accident.

On any work not performed by BARKER PRODUCTS or it's representative, the customer will be responsible for freight charges on all parts shipped under warranty. Parts will be invoiced at time of shipment. Defective parts must be returned to BARKER PRODUCTS within 30 days. If the part is determined to be defective the customer will be credited for the original invoice.

Customer warranty labor charges must be approved by BARKER PRODUCTS in advance. If not contacted for approval, BARKER PRODUCTS will not be liable for the warranty labor charge.

Limit hydraulic input pressure to 2000PSI