

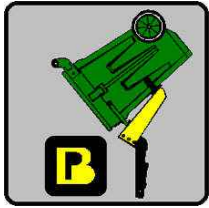

BP LIFTS
BY BARKER PRODUCTS
1310 Miller Road, Greenville, SC 29607
Phone:800-349-3149—Fax:864-297-1292



BPH2-27 SERIES LIFTS



***Powered By A 27K Helical Actuator
With
Splined Shafts To Eliminate Arm Movement & Wear
For
Extreme Heavy Duty High Lift Applications
45" To 57" Mounting Heights
50" To 74" Dump Heights
Over 50 Degree Dump Angle To Empty Can Quickly
Dumps Deep Into Hopper to Prevent Spillage
Hardened Steel Bearings At All Pivot Points***

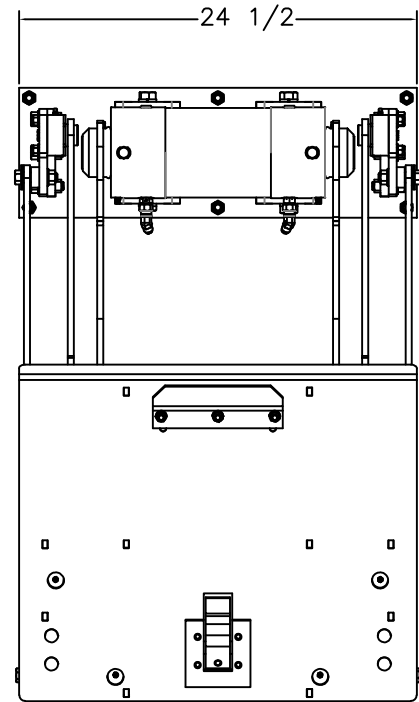
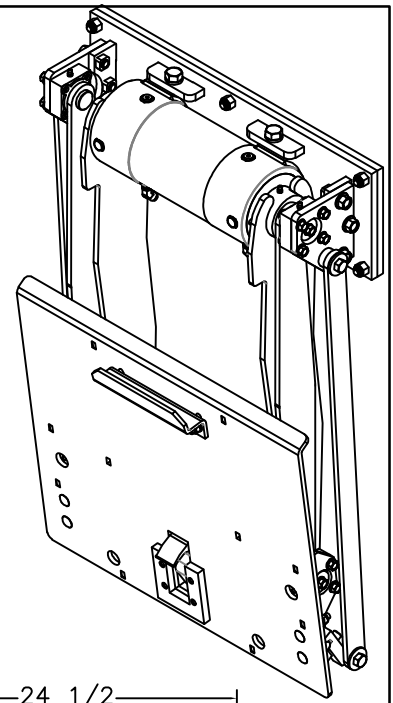
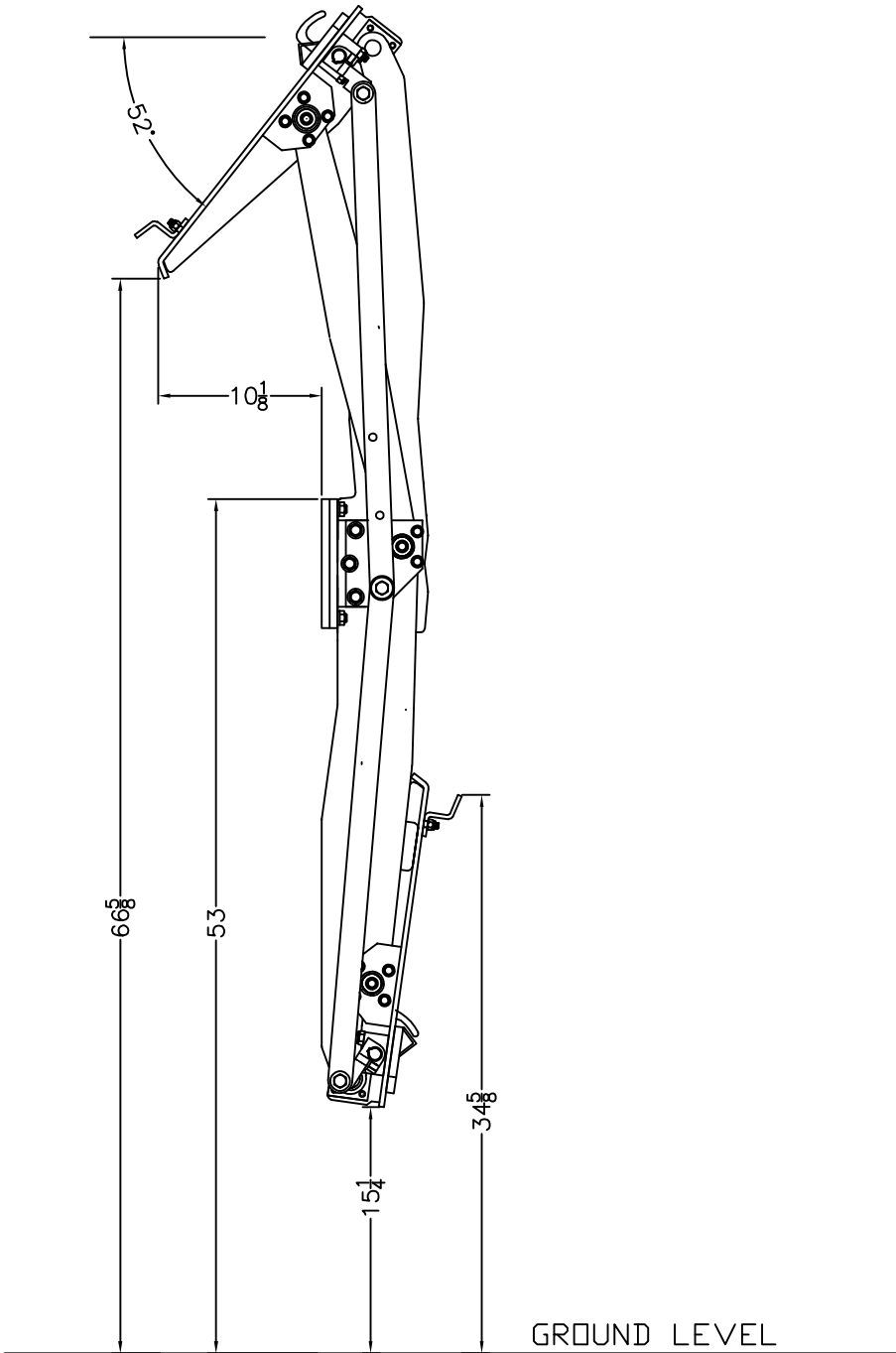

BARKER PRODUCTS
1310 MILLER ROAD
GREENVILLE, SC
29607

DRAWN BY: R WYMAN
DATE: 10/9/2018
MATERIAL: NOTED

DO NOT SCALE
DRAWING
UNLESS OTHERWISE SPECIFIED:
DIMENSIONS ARE IN INCHES
TOLERANCES:
FRACTIONAL ±1/32
ANGULAR: MACH ±1° BEND ±1°
TWO PLACE DECIMAL ±0.010
THREE PLACE DECIMAL ±0.005

H2-2753 LIFT UNIT		
DRAWING NO BU18653 ENVELOPE		REV 00
SCALE: 1:12	WEIGHT: 206.215 #	SHEET 1 OF 1

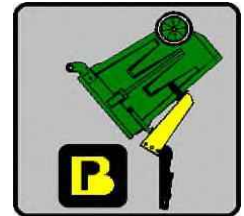
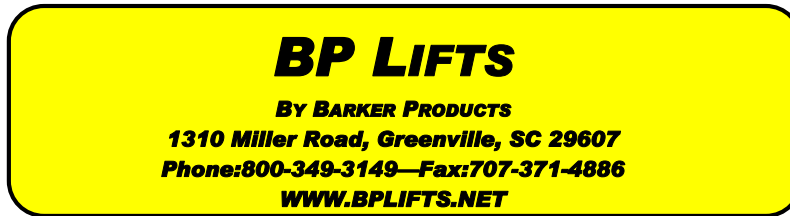

Lift Unit Installation

1. Truck must be empty, clean and parked on a level surface before installation is started.
2. Remove all bumpers and running boards that will interfere with the location of the lift units. Relocate lower mounted tail lights as needed.
3. Measure and mark the centerline of the truck hopper. The centerline of the unit or units should be a minimum of 17" from the hopper centerline.
4. Hand valves should be mounted on the side of the hopper at the most convenient height for the operator and clear of the packer controls.
5. The top of the unit mounting plate should be tack welded in place at the height recommended on the envelope dimension sheet of the unit.
CAUTION: SEE NOTE BELOW PICTURE
6. All dimensions should be approved by the customer before final welding.
7. If the mounting plate extends more than 2" above the hopper, a brace should be added.

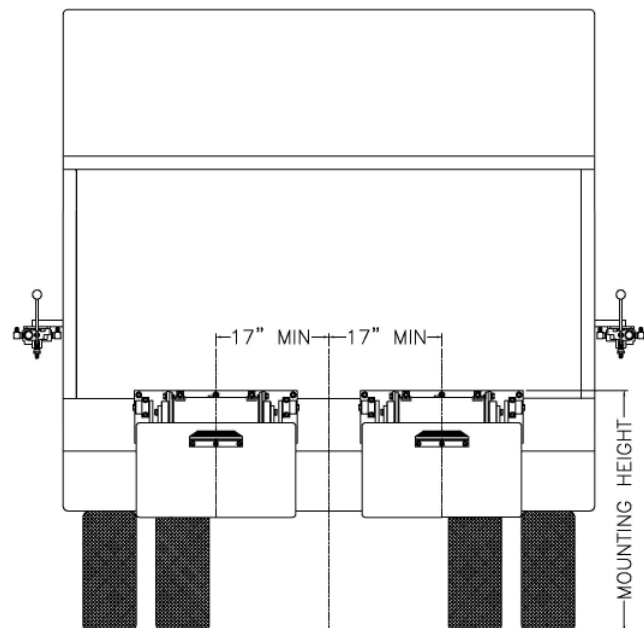

Mounting heights and locations are recommendations only. It is the responsibility of the installer to insure that the customer is satisfied with the height. Barker Products recommends that after the units are tacked in place, try the units with the can or cans the customer uses. The customer should approve your mount before final welding.

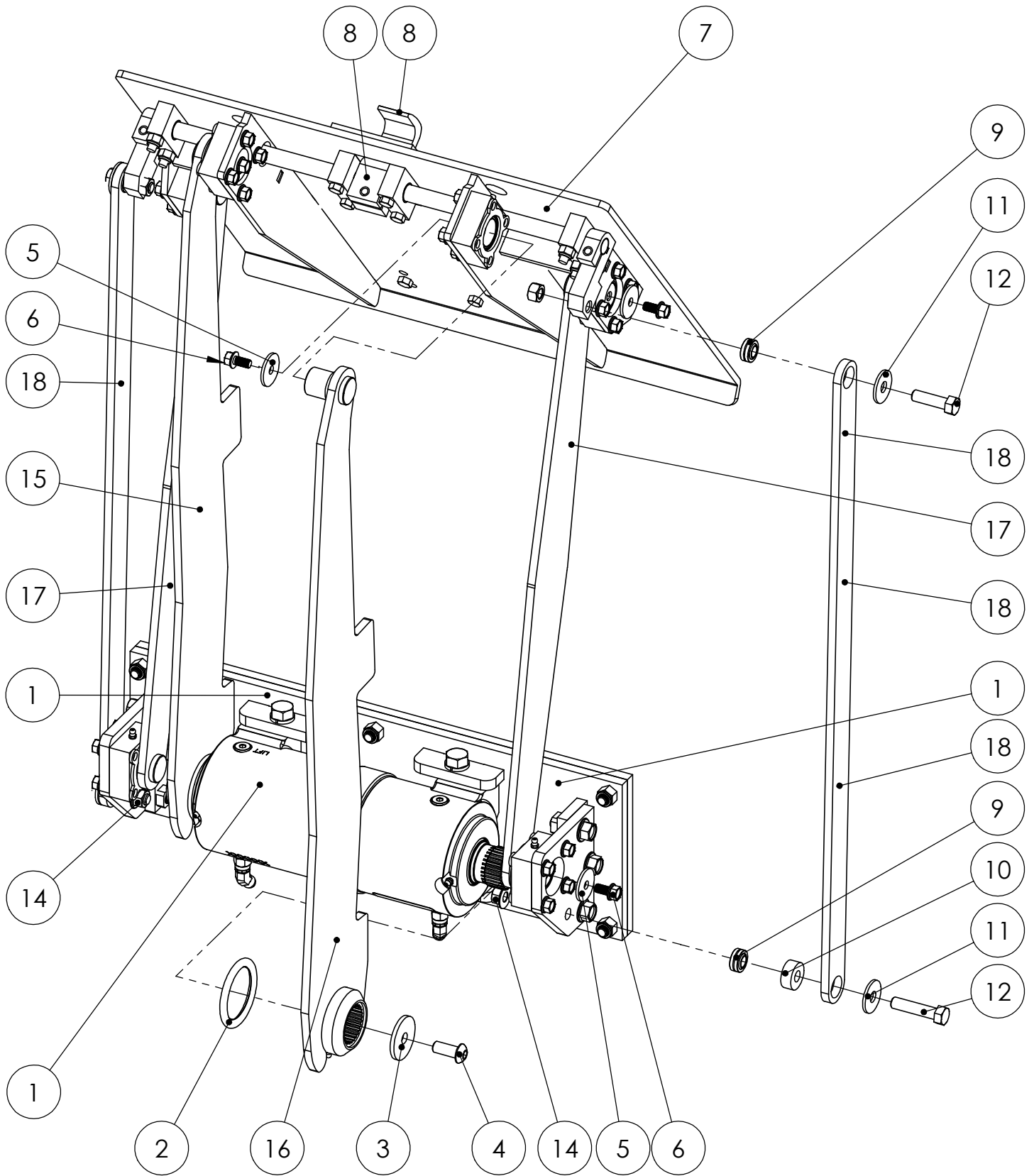

DO NOT SCALE DRAWING		H2-2753 LIFT UNIT	
UNLESS OTHERWISE SPECIFIED: DIMENSIONS ARE IN INCHES TOLERANCES: FRACTIONAL $\pm 1/32$ ANGULAR: MACH $\pm 1^\circ$ BEND $\pm 1^\circ$ TWO PLACE DECIMAL ± 0.010 THREE PLACE DECIMAL ± 0.005		DRAWING NO BU18653 PARTS	REV 00
MATERIAL: NOTED		SCALE: 1:6	WEIGHT: 282.320 # SHEET 1 OF 2



BARKER PRODUCTS
1310 MILLER ROAD
GREENVILLE, SC
29607

DRAWN BY: R WYMAN
DATE: 9/4/2018
MATERIAL: NOTED

ITEM NO.	PART NUMBER	DESCRIPTION	EXPLODED PARTS/QTY.
1	BWA18505	MAINFRAME SUB ASSY H2-27XX	1
2	BW18002	O-RING GREASE SEAL	2
3	BZ18005	SPLINE CAP H2-25 UNITS	2
4	XAC081310	1/2-13 X 1 1/4 BHCS	2
5	XEA062412SS	FLAT WASHER 3/8 X 1 1/2 X 1/8	6
6	XAE061606	3/8-16 X 3/4 FLANGED HHCS	6
7	BWA18540	LIFT PLATE SUB ASSY	1
8	BWA07490	HOOK SUB ASSY	1
9	BW99108	1/2" SPHERICAL BEARING	4
10	BW18520	HOOK LINK DRIVE SPACER	2
11	XEA082412SS	FLAT WASHER 1/2 X 1 1/2 X 1/8	4
12	XAA081314	1/2-13 X 1 3/4 HHCS	4
13	XDA081300	1/2-13 HEX NUT	2
14	XDH081300	1/2-13 FLANGED NUT	2
15	BW18600	LEFT LIFT ARM	1
16	BW18610	RIGHT LIFT ARM	1
17	BW18660	GUIDE ARM	2
18	BW18700	HOOK LINK	2



BARKER PRODUCTS
1310 MILLER ROAD
GREENVILLE, SC
29607

DRAWN BY: R WYMAN
DATE: 9/4/2018
MATERIAL: NOTED

DO NOT SCALE
DRAWING
UNLESS OTHERWISE SPECIFIED:
DIMENSIONS ARE IN INCHES
TOLERANCES:
FRACTIONAL ±1/32
ANGULAR: MACH ±1° BEND ±1°
TWO PLACE DECIMAL ±0.010
THREE PLACE DECIMAL ±0.005

H2-2753 LIFT UNIT
DRAWING NO
BU18653 PARTS
SCALE: 1:6 WEIGHT: 282.320 # SHEET 2 OF 2
REV
00

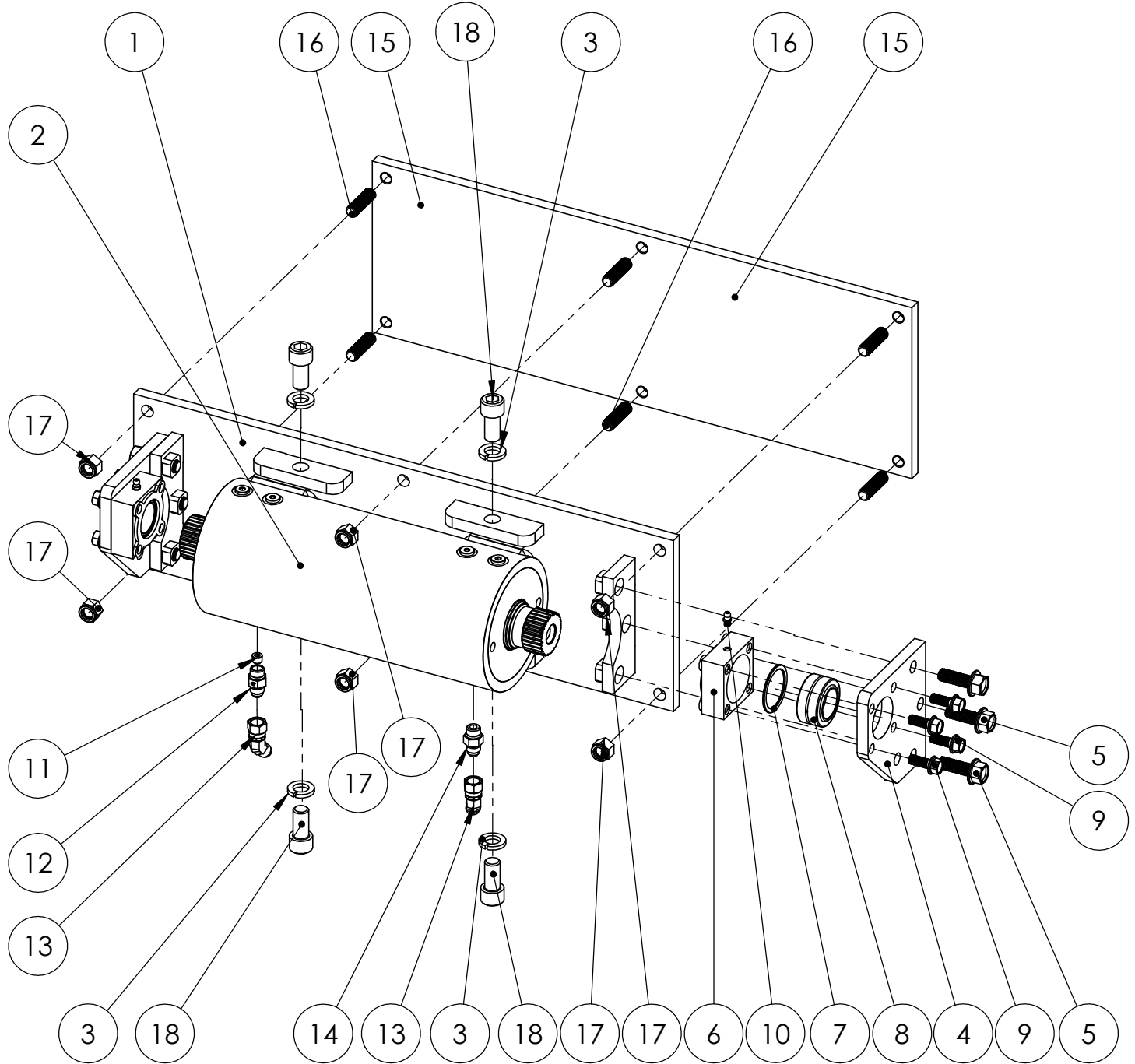

DO NOT SCALE DRAWING UNLESS OTHERWISE SPECIFIED: DIMENSIONS ARE IN INCHES TOLERANCES: FRACTIONAL $\pm 1/32$ ANGULAR: MACH $\pm 1^\circ$ BEND $\pm 1^\circ$ TWO PLACE DECIMAL ± 0.010 THREE PLACE DECIMAL ± 0.005	MAINFRAME SUB ASSY H2-27 T30-27 ACTUATOR		REV 00
	DRAWING NO BWA18505 PARTS		
	SCALE: 1:6	WEIGHT: 148.424 #	SHEET 1 OF 2



BARKER PRODUCTS
 1310 MILLER ROAD
 GREENVILLE, SC
 29607

DRAWN BY: R WYMAN
 DATE: 3/18/2020
 MATERIAL: NOTED

ITEM NO.	PART NUMBER	DESCRIPTION	EXPLODED VIEW/QTY.
1	BW18505	MAINFRAME T30-27XX	1
2	BW18300	ACTUATOR	1
3	XEB101000	5/8 LOCKWASHER	4
4	BW18510	BEARING MOUNT	2
5	XAE081312	1/2-13 X 1 1/2 FLANGED HHCS	6
6	BW18530	BEARING BODY	2
7	BW21065	PIVOT BEARING SPACER	2
8	BW99320	SPHERICAL BEARING 1 1/4	2
9	XAE061608	3/8-16 X 1 FLANGED HHCS	8
10	BW01110	GREASE FITTING - 1/4-28 SHORT	2
11	BV00025	1 1/6 X 1/8 NPT ORIFICE PLUG	1
12	BV00064	6T X 6S ORIFICE FITTING	1
13	BR04842	6502-06-06 MJ-FJS 45 DEG	2
14	BR03830	6400-06-06 M TUBE O-RING	1
15	BW07030	MOUNT PLATE H	1
16	BW07140	PLATE STUD	6
17	XDC082000	1/2-20 NYLOK NUT	6
18	XAB101110	5/8-11 X 1 1/4 SHCS	4



BARKER PRODUCTS
1310 MILLER ROAD
GREENVILLE, SC
29607

DRAWN BY: R WYMAN
DATE: 3/18/2020
MATERIAL: NOTED

DO NOT SCALE
DRAWING
UNLESS OTHERWISE SPECIFIED:
DIMENSIONS ARE IN INCHES
TOLERANCES:
FRACTIONAL ±1/32
ANGULAR: MACH ±1° BEND ±1°
TWO PLACE DECIMAL ±0.010
THREE PLACE DECIMAL ±0.005

MAINFRAME SUB ASSY H2-27
T30-27 ACTUATOR
DRAWING NO
BWA18505 PARTS
SCALE: 1:4 WEIGHT: 148.424 # SHEET 2 OF 2
REV
00

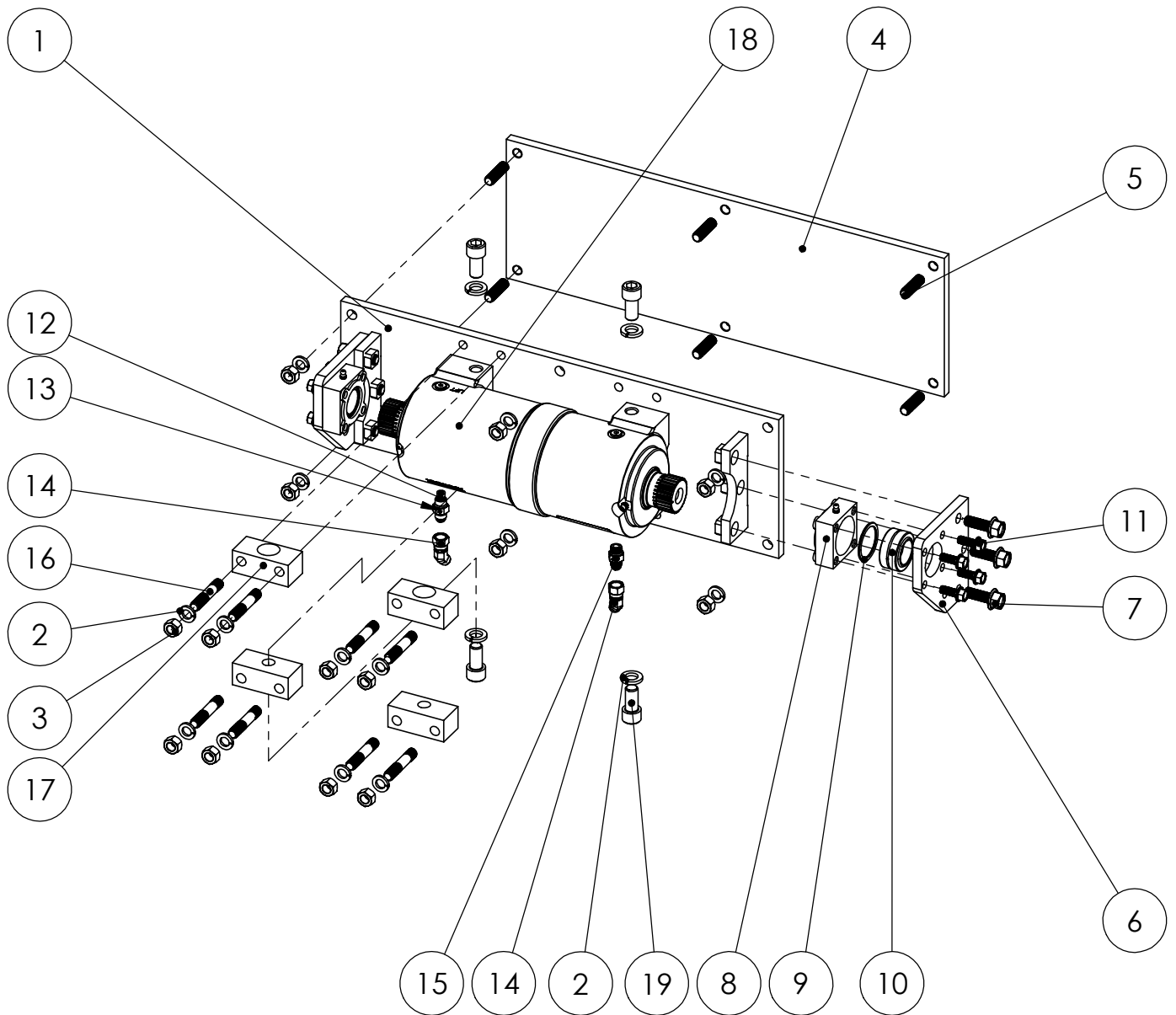

BARKER PRODUCTS
 1310 MILLER ROAD
 GREENVILLE, SC
 29607

DRAWN BY: R WYMAN
 DATE: 4/12/2022
 MATERIAL: NOTED

DO NOT SCALE
 DRAWING
 UNLESS OTHERWISE SPECIFIED:
 DIMENSIONS ARE IN INCHES
 TOLERANCES:
 FRACTIONAL $\pm 1/32$
 ANGULAR: MACH $\pm 1^\circ$ BEND $\pm 1^\circ$
 TWO PLACE DECIMAL ± 0.010
 THREE PLACE DECIMAL ± 0.005

MAINFRAME SUB ASSY
 BU186XX

DRAWING NO
 BWA18506 PARTS

REV
 00

SCALE: 1:8 WEIGHT: 140.251 # SHEET 1 OF 2

PART NUMBER	ITEM NO.	DESCRIPTION	QTY.
BW18506	1	MAINFRAME	1
XEB081000	2	1/2 LOCKWASHER	14
XDA082000	3	1/2-20 HEX NUT	14
BW07030	4	MOUNT PLATE H	1
BW07140	5	PLATE STUD	6
BW18510	6	BEARING MOUNT	2
XAE081312	7	1/2-13 X 1 1/2 FLANGED HHCS	6
BW18530	8	BEARING BODY	2
BW21065	9	PIVOT BEARING SPACER	2
BW99320	10	SPHERICAL BEARING 1 1/4	2
XAE061608	11	3/8-16 X 1 FLANGED HHCS	8
BV00025	12	1 1/2 X 1/8 NPT ORIFICE PLUG	2
BV00064	13	6T X 6S ORIFICE FITTING	1
BR04842	14	6502-06-06 MJ-FJS 45 DEG	2
BR03830	15	6400-06-06 M TUBE TO O-RING	1
BW07105	16	ACTUATOR MOUNT STUD	8
BW18013	17	27K ACTUATOR MT BRKT	4
BW18300	18	27K HELICAL ACTUATOR	1
XAB101110	19	5/8-11 X 1 1/4 SHCS	4
XEB101000	20	5/8 HIGH COLLAR LOCKWASHER	4



BARKER PRODUCTS
1310 MILLER ROAD
GREENVILLE, SC
29607

DRAWN BY: R WYMAN

DATE: 4/12/2022

MATERIAL: NOTED

DO NOT SCALE
DRAWING

UNLESS OTHERWISE SPECIFIED:
DIMENSIONS ARE IN INCHES
TOLERANCES:
FRACTIONAL ±1/32
ANGULAR: MACH ±1° BEND ±1°
TWO PLACE DECIMAL ±0.010
THREE PLACE DECIMAL ±0.005

MAINFRAME SUB ASSY
BU186XX

DRAWING NO
BWA18506 PARTS

REV
00

SCALE: 1:8

WEIGHT: 140.251 #

SHEET 2 OF 2

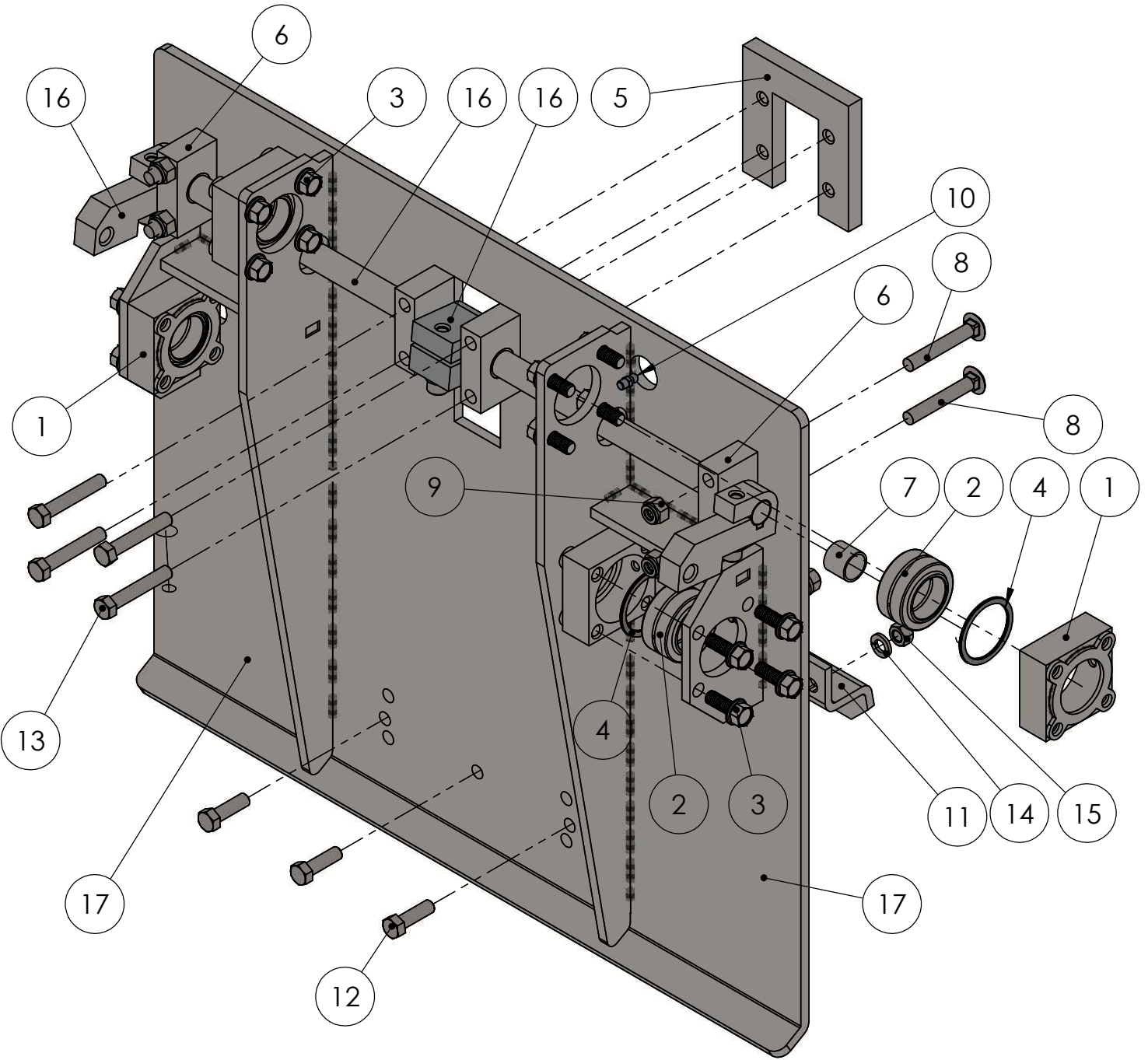

	BARKER PRODUCTS 1310 MILLER ROAD GREENVILLE, SC 29607		DO NOT SCALE DRAWING	LIFT PLATE SUB ASSY H2-25 LIFTS	
	DRAWN BY: R WYMAN	DATE: 8/1/2017	UNLESS OTHERWISE SPECIFIED: DIMENSIONS ARE IN INCHES TOLERANCES: FRACTIONAL $\pm 1/32$ ANGULAR: MACH $\pm 1^\circ$ BEND $\pm 1^\circ$ TWO PLACE DECIMAL ± 0.010 THREE PLACE DECIMAL ± 0.005	DRAWING NO BWA18540	REV 01
	MATERIAL: NOTED			SCALE: 1:4	WEIGHT: 74.297 #
				SHEET 1 OF 2	

ITEM NO.	PART NUMBER	DESCRIPTION	EXPLODED PARTS/QTY.
1	BW18530	BEARING BODY	4
2	BW99320	SPHERICAL BEARING 1 1/4	4
3	XAE061608	3/8-16 X 1 FLANGED HHCS	16
4	BW21065	PIVOT BEARING SPACER	4
5	BZ03451	SUPPORT PLATE	1
6	BW17130	HOOK BEARING MOUNT	4
7	BW03195	12-DU-12 BEARING	4
8	XAH061620	3/8-16 X 2 1/2 CARRIAGE BOLT	4
9	XDC061600	3/8-16 NYLOK NUT	4
10	BW01110	GREASE FITTING - 1/4-28 SHORT	4
11	BW00800	SADDLE	1
12	XAA061610	3/8-16 X 1 1/4 HHCS	3
13	XAA061618	3/8-16 X 2 1/4 HHCS	4
14	XEB061000	3/8 LOCKWASHER	3
15	XDA061600	3/8-16 HEX NUT	3
16	BWA07490	HOOK SUB ASSY	1
17	BW18540	LIFT PLATE	1



BARKER PRODUCTS
1310 MILLER ROAD
GREENVILLE, SC
29607

DRAWN BY: R WYMAN
DATE: 8/1/2017
MATERIAL: NOTED

DO NOT SCALE
DRAWING
UNLESS OTHERWISE SPECIFIED:
DIMENSIONS ARE IN INCHES
TOLERANCES:
FRACTIONAL ±1/32
ANGULAR: MACH ±1° BEND ±1°
TWO PLACE DECIMAL ±0.010
THREE PLACE DECIMAL ±0.005

LIFT PLATE SUB ASSY
H2-25 LIFTS
DRAWING NO
BWA18540
SCALE: 1:6 WEIGHT: 74.297 # SHEET 2 OF 2
REV
01

ITEM NO.	PART NUMBER	DESCRIPTION	EXPLODED PARTS/QTY.
1	BW18550	HOOK SHAFT	1
2	BW07560	WOODRUFF KEY #806	3
3	BW07490	HOOK	1
4	BW06780	HOOK DRIVE	2
5	XEB061000	3/8 LOCKWASHER	3
6	XAB061612	3/8-16 X 1 1/2 SHCS	3

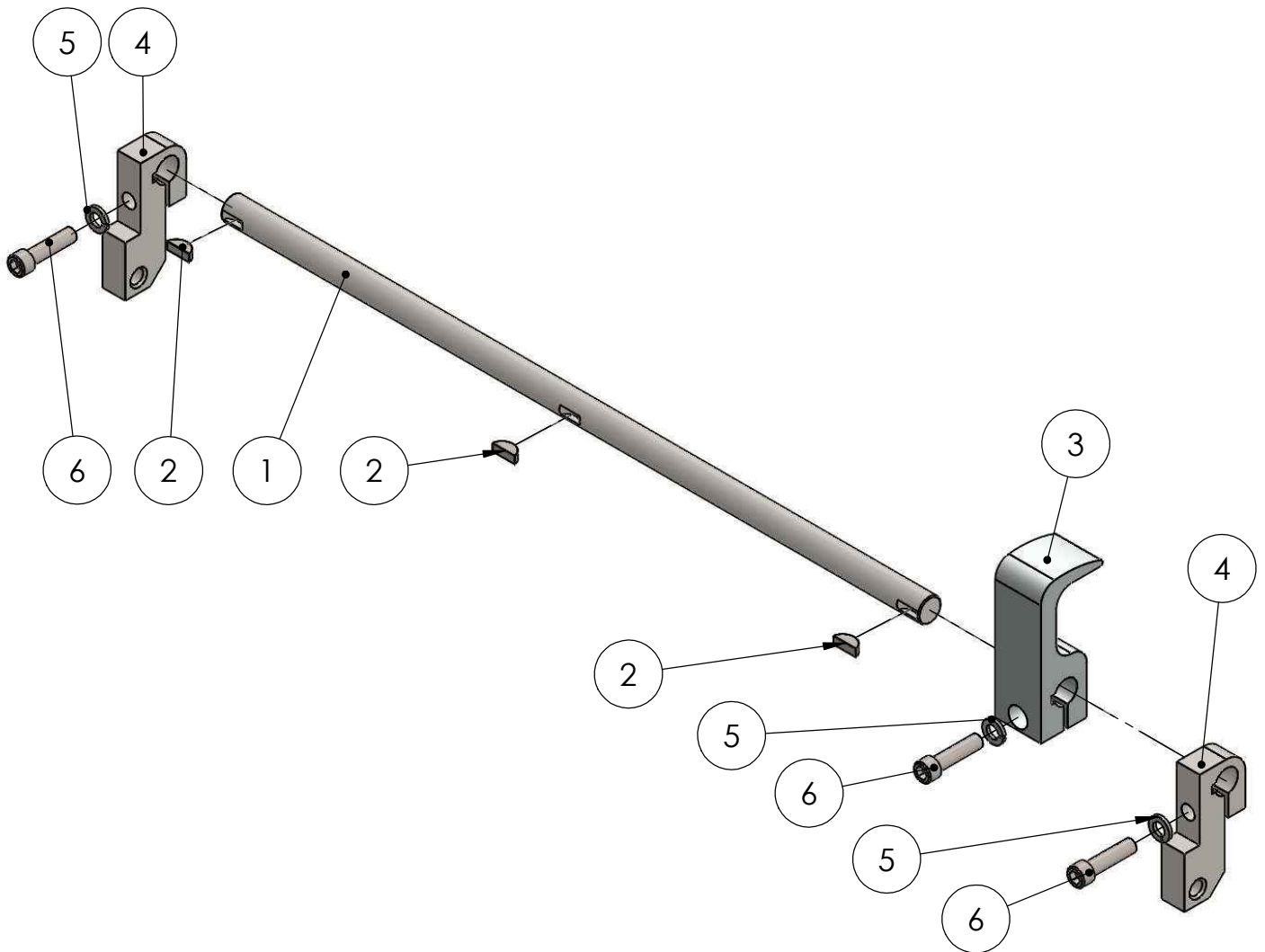

DO NOT SCALE DRAWING		HOOK SUB ASSY H2-25	
UNLESS OTHERWISE SPECIFIED: DIMENSIONS ARE IN INCHES TOLERANCES: FRACTIONAL $\pm 1/32$ ANGULAR: MACH $\pm 1^\circ$ BEND $\pm 1^\circ$ TWO PLACE DECIMAL ± 0.010 THREE PLACE DECIMAL ± 0.005		DRAWING NO BWA07490	REV 00
SCALE: 1:4	WEIGHT: 6.177 #	SHEET 1 OF 1	



BARKER PRODUCTS
1310 MILLER ROAD
GREENVILLE, SC
29607

DRAWN BY: R WYMAN
DATE: 8/1/2017
MATERIAL: NOTED

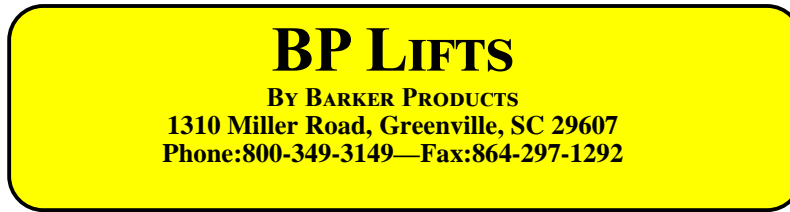

BPH27-186XX SERIES LIFT UNIT WARRANTY

Barker Products warrants each new dump unit to be free of defects in material and workmanship under normal use and service for a period of 1 year or 2000 hours of operation, whichever comes first, from the date of delivery.

This warranty excludes any obligations by BARKER PRODUCTS for the cost of down time. BARKER PRODUCTS will not warranty any dump unit which has been subject to misuse, neglect, alteration, or damaged by an accident.

On any work not performed by BARKER PRODUCTS or it's representative, the customer will be responsible for freight charges on all parts shipped under warranty. Parts will be invoiced at time of shipment. Defective parts must be returned to BARKER PRODUCTS within 30 days. If the part is determined to be defective the customer will be credited for the original invoice.

Customer warranty labor charges must be approved by BARKER PRODUCTS in advance. If not contacted for approval, BARKER PRODUCTS will not be liable for the warranty labor charge.

Limit hydraulic input pressure to 2000PSI