



BP Lifts
By Barker Products
1310 Miller Road, Greenville, SC 29607



Model HB27-8041 Lift

Part # BU18741



- Dependable Smooth Acting 25K Helical Rotary Actuator
- Splined Shafts To Eliminate Arm Movement And Wear
- 45 Degree Dump Angle
- No Grease Points
- EZ Bolt On Kit Standard
- Meets ANSI Z245 Type B Specs Lifts All Standard American 2 Bar Carts
- Liftplate Arc Motion Makes Cart Attachment Fast And Easy On Unlevel Highway Conditions
- Double Wide Mounting Plate Available. Increases Hopper Height To Decrease Packing Cycles
- 38 to 44 Inch Mounting Height
- 18 1/2 to 24 1/2 Inch Ground Clearance
- Use on Rear Loaders

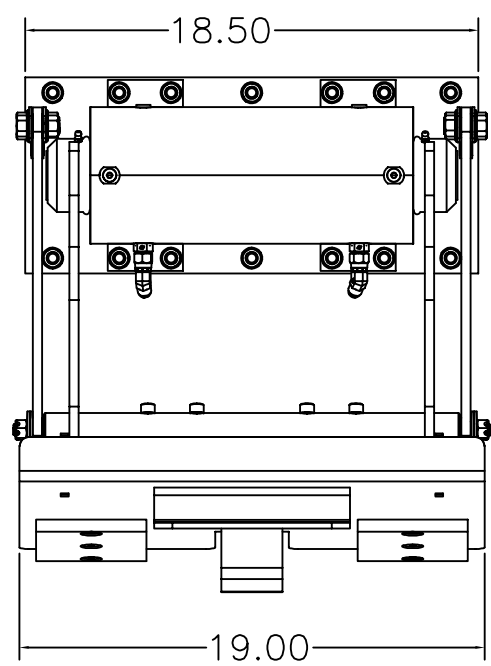
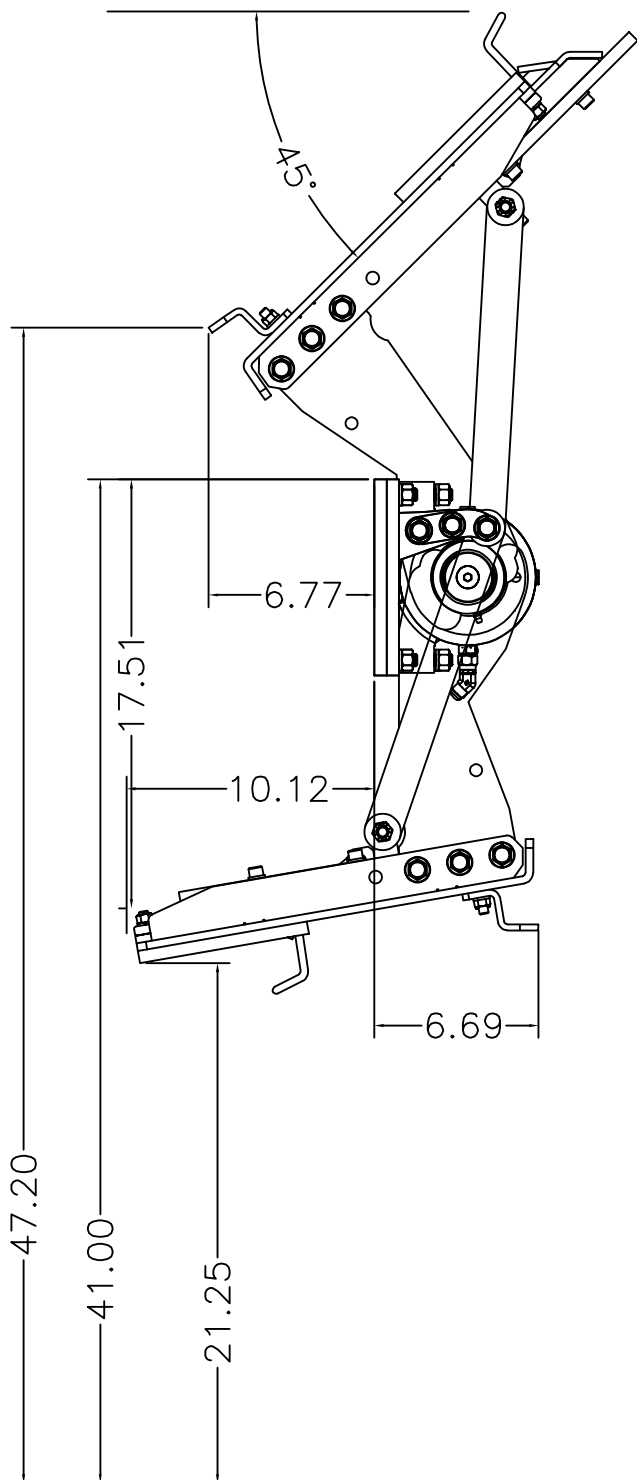
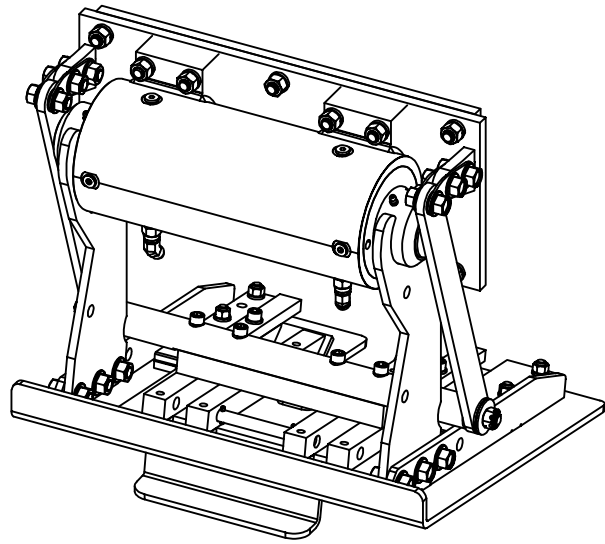

BARKER PRODUCTS
1310 MILLER ROAD
GREENVILLE, SC
29607

DRAWN BY: R WYMAN
DATE: 9/22/2022
MATERIAL: NOTED

DO NOT SCALE
DRAWING
UNLESS OTHERWISE SPECIFIED
DIMENSIONS ARE IN INCHES
TOLERANCES:
FRACTIONAL ±1/32
ANGULAR: MACH ±1° BEND ±1°
TWO PLACE DECIMAL ±0.010
THREE PLACE DECIMAL ±0.005

HB27-8041 LIFT
BW18400 ACTUATOR

DRAWING NO
BU18741

REV
00

SCALE: 1:8

WEIGHT: 215.152 #

SHEET 1 OF 1

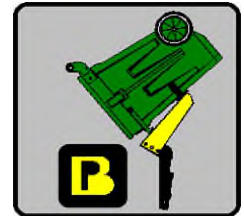
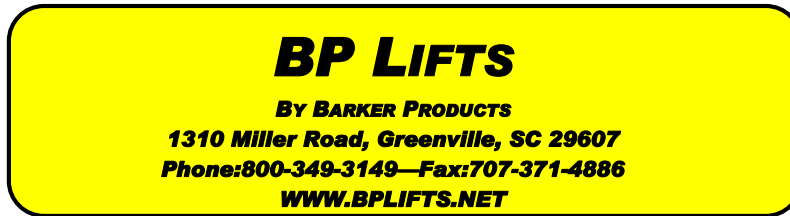

Lift Unit Installation

1. Truck must be empty, clean and parked on a level surface before installation is started.
2. Remove all bumpers and running boards that will interfere with the location of the lift units. Relocate lower mounted tail lights as needed.
3. Measure and mark the centerline of the truck hopper. The centerline of the unit or units should be a minimum of 17" from the hopper centerline.
4. Hand valves should be mounted on the side of the hopper at the most convenient height for the operator and clear of the packer controls.
5. The top of the unit mounting plate should be tack welded in place at the height recommended on the envelope dimension sheet of the unit.
CAUTION: SEE NOTE BELOW PICTURE
6. All dimensions should be approved by the customer before final welding.
7. If the mounting plate extends more than 2" above the hopper, a brace should be added.

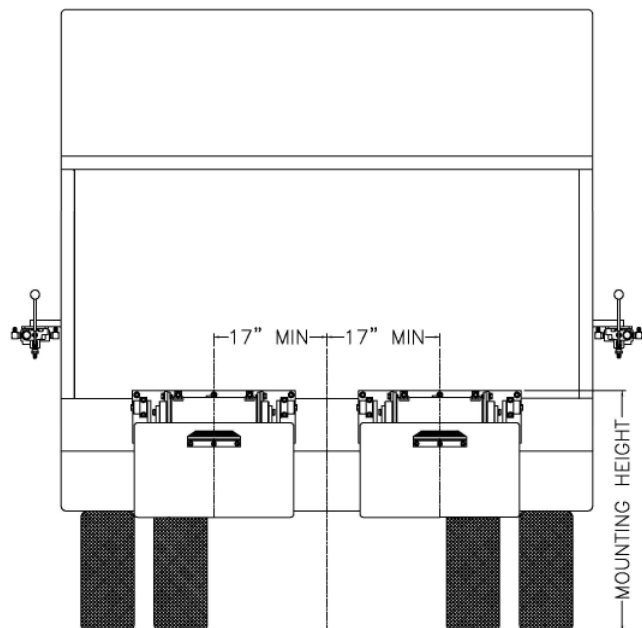

Mounting heights and locations are recommendations only. It is the responsibility of the installer to insure that the customer is satisfied with the height. Barker Products recommends that after the units are tacked in place, try the units with the can or cans the customer uses. The customer should approve your mount before final welding.

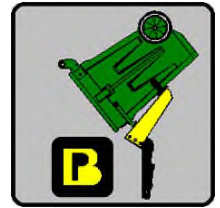
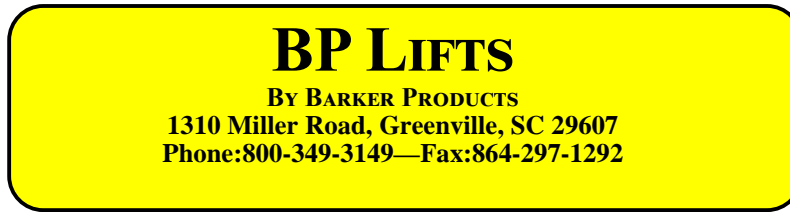

BPHB27-183XX SERIES LIFT UNIT WARRANTY

Barker Products warrants each new dump unit to be free of defects in material and workmanship under normal use and service for a period of 1 year or 2000 hours of operation, whichever comes first, from the date of delivery.

This warranty excludes any obligations by BARKER PRODUCTS for the cost of down time. BARKER PRODUCTS will not warranty any dump unit which has been subject to misuse, neglect, alteration, or damaged by an accident.

On any work not performed by BARKER PRODUCTS or it's representative, the customer will be responsible for freight charges on all parts shipped under warranty. Parts will be invoiced at time of shipment. Defective parts must be returned to BARKER PRODUCTS within 30 days. If the part is determined to be defective the customer will be credited for the original invoice.

Customer warranty labor charges must be approved by BARKER PRODUCTS in advance. If not contacted for approval, BARKER PRODUCTS will not be liable for the warranty labor charge.

Limit hydraulic input pressure to 1700 PSI

ITEM NO.	PART NUMBER	DESCRIPTION	QTY.
1	BW18014	MAINFRAME	1
2	BW07105	ACTUATOR MOUNT STUD	8
3	XEB081000	1/2 LOCK WASHER	14
4	XDA082000	1/2-20 HEX NUT	14
5	BW18400	ACTUATOR	1
6	BW17525	MOUNT PLATE - N	1
7	BW07140	PLATE STUD	6
8	BV00025	1 1/6 X 1/8 NPT ORIFICE PLUG	2
9	BV00064	6T X 6S ORIFICE FITTING	1
10	BR04842	6502-06-06 MJ-FJS 45 DEG	2
11	BR03830	6400-06-06 M TUBE TO O-RING	1

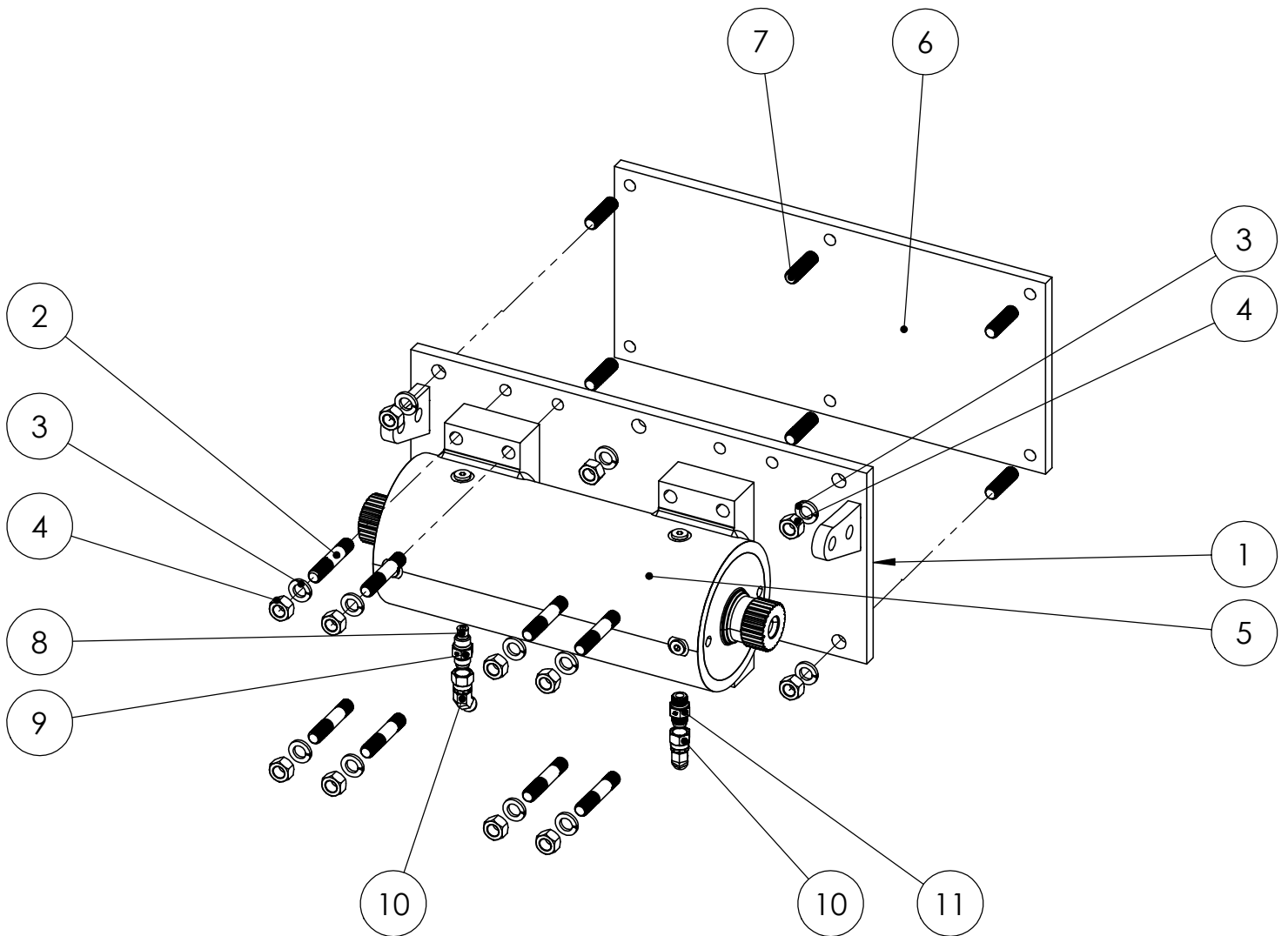

DO NOT SCALE DRAWING		MAINFRAME SUB ASSY BU18XXX	
UNLESS OTHERWISE SPECIFIED: DIMENSIONS ARE IN INCHES TOLERANCES: FRACTIONAL ±1/32 ANGULAR: MACH ±1° BEND ±1° TWO PLACE DECIMAL ±0.010 THREE PLACE DECIMAL ±0.005		DRAWING NO BWA18414 PARTS	REV 00
SCALE: 1:6		WEIGHT: 121.079 #	SHEET 1 OF 1



BARKER PRODUCTS
1310 MILLER ROAD
GREENVILLE, SC
29607

DRAWN BY: R WYMAN
DATE: 6/2/2022
MATERIAL: NOTED

ITEM NO.	PART NUMBER	DESCRIPTION	EXPLODED PARTS/QTY.
1	BW18090	LIFT PLATE	1
2	BW00800	SADDLE	1
3	XAB061610	3/8-16 X 1 1/4 SHCS	3
4	XEB061000	3/8 LOCKWASHER	9
5	XDA061600	3/8-16 HEX NUT	9
6	BW10675	CAN SUPPORT	2
7	XAD061616	3/8-16 X 2 FSHCS	6
8	BW19110	SLIDE SPACER	2
9	BW19100	SLIDE CAP	2

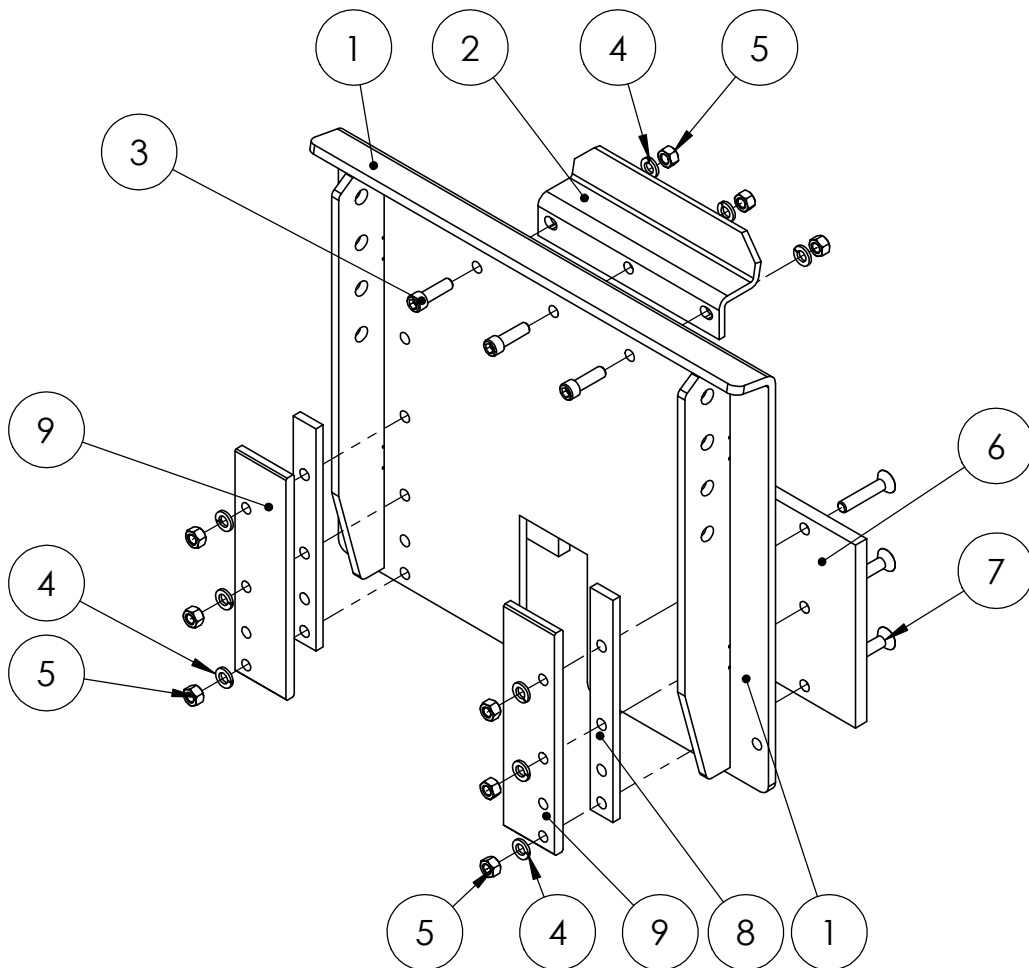

DO NOT SCALE DRAWING		LIFT PLATE SUB ASSY HB25	
UNLESS OTHERWISE SPECIFIED: DIMENSIONS ARE IN INCHES TOLERANCES: FRACTIONAL ±1/32 ANGULAR: MACH ±1° BEND ±1° TWO PLACE DECIMAL ±0.010 THREE PLACE DECIMAL ±0.005		DRAWING NO BWA18090	REV 00
SCALE: 1:6		WEIGHT: 41.513 #	SHEET 1 OF 1



BARKER PRODUCTS
1310 MILLER ROAD
GREENVILLE, SC
29607

DRAWN BY: R WYMAN
DATE: 7/12/2017
MATERIAL: NOTED

ITEM NO.	PART NUMBER	DESCRIPTION	EXPLODE VIEW/QTY.
1	BW10230	SLIDE PLATE	1
2	BW10240	SLIDE SUPPORT	4
3	XAD061606	3/8-16 X 3/4 FHSCS	12
4	BW10110	SPRING SHAFT	1
5	BW10680	HOOK	1
6	BW10100	HOOK SHAFT	1
7	BW02125	5/32 X 3/4 SPRING PIN	4
8	BW10120	HOOK SPRING	2
9	BW10690	SLIDE EXTENSION	2
10	XEB061000	3/8 LOCKWASHER	4
11	XAB061608	3/8-16 X 1 SHCS	4
12	XAB061620	3/8-16 X 2 1/2 SHCS	4
13	BW18080	HOOK MOUNT	1
14	BW18075	SLIDE DRIVE	1
15	XEC0606080	3/8 HC LOCKWASHER	4

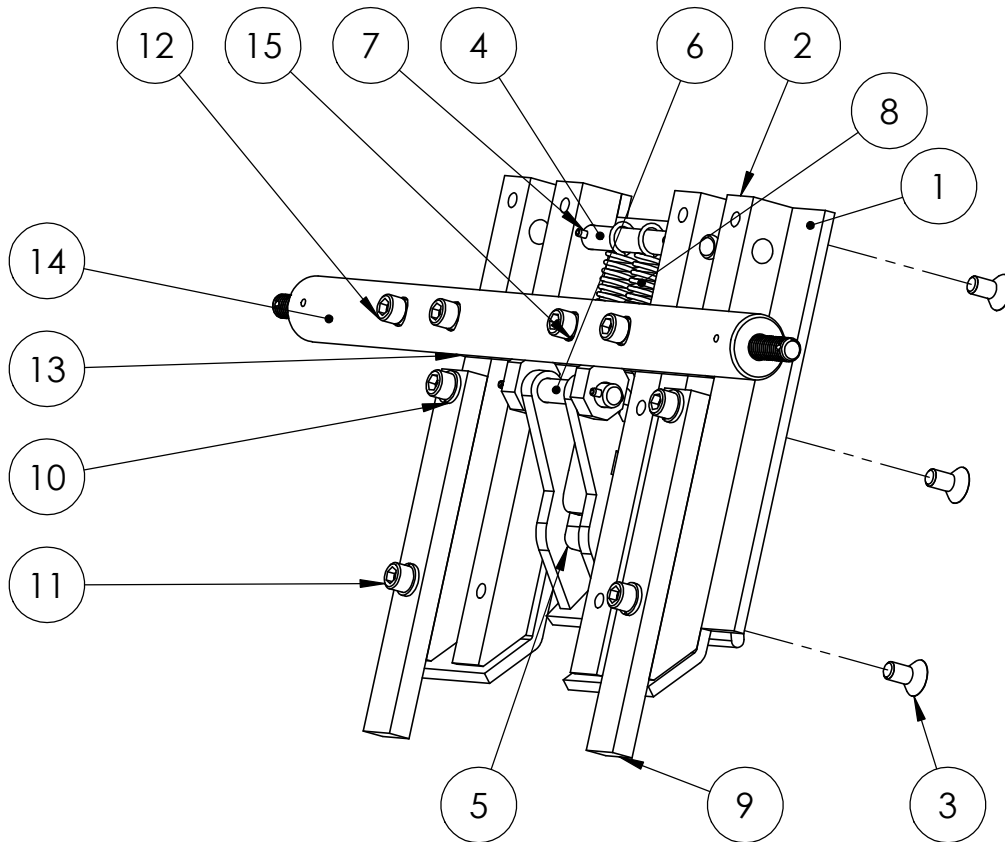

DO NOT SCALE DRAWING		SLIDE PARTS 25K UNITS	
UNLESS OTHERWISE SPECIFIED: DIMENSIONS ARE IN INCHES TOLERANCES: FRACTIONAL ±1/32 ANGULAR: MACH ±1° BEND ±1° TWO PLACE DECIMAL ±0.010 THREE PLACE DECIMAL ±0.005		DRAWING NO BW19000	REV 00
SCALE: 1:4	WEIGHT: 30.667 #	SHEET 1 OF 1	



BARKER PRODUCTS
1310 MILLER ROAD
GREENVILLE, SC
29607

DRAWN BY: R WYMAN
DATE: 7/12/2017
MATERIAL: NOTED