

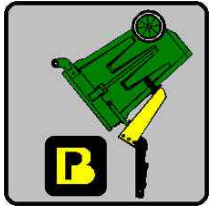

**BP LIFTS**  
BY BARKER PRODUCTS  
1310 Miller Road, Greenville, SC 29607  
Phone:800-349-3149—Fax:864-297-1292



# ***BPH2-27 SERIES LIFTS***



***Powered By A 27K Helical Actuator  
With  
Splined Shafts To Eliminate Arm Movement & Wear  
For  
Extreme Heavy Duty High Lift Applications  
45" To 57" Mounting Heights  
50" To 74" Dump Heights  
Over 50 Degree Dump Angle To Empty Can Quickly  
Dumps Deep Into Hopper to Prevent Spillage  
Hardened Steel Bearings At All Pivot Points***

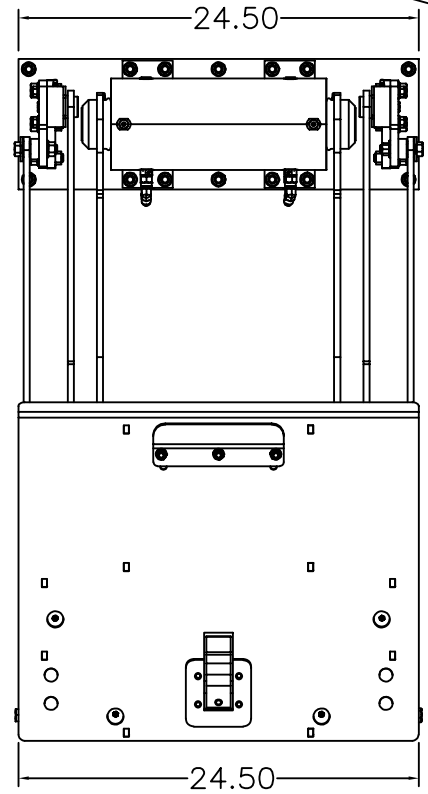
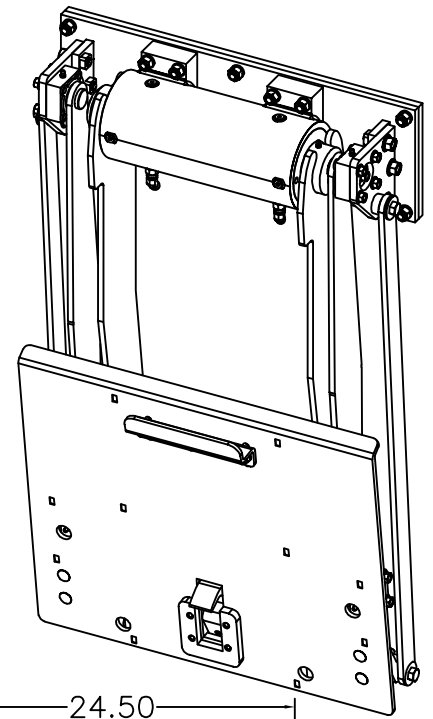
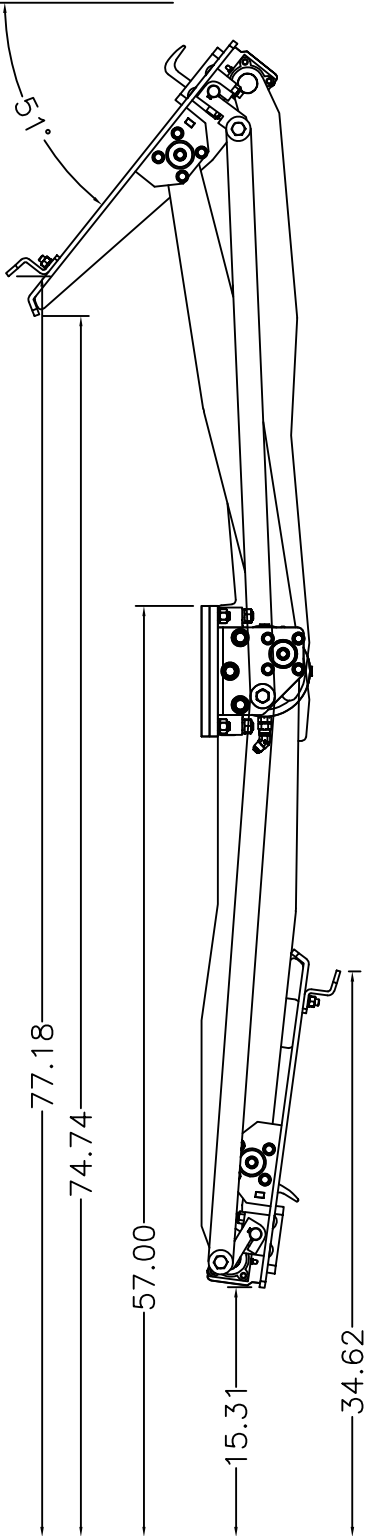

BARKER PRODUCTS  
1310 MILLER ROAD  
GREENVILLE, SC  
29607

DRAWN BY: R WYMAN  
DATE: 9/20/2022  
MATERIAL: NOTED

DO NOT SCALE  
DRAWING  
UNLESS OTHERWISE SPECIFIED,  
DIMENSIONS ARE IN INCHES  
TOLERANCES:  
FRACTIONAL ±1/32  
ANGULAR: MACH ±1° BEND ±1°  
TWO PLACE DECIMAL ±0.010  
THREE PLACE DECIMAL ±0.005

BU18957 LIFT  
BW18400 ACTUATOR

DRAWING NO  
BU18957

REV  
00

SCALE: 1:12

WEIGHT: 293.904 #

SHEET 1 OF 1

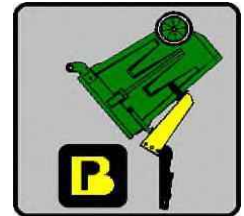
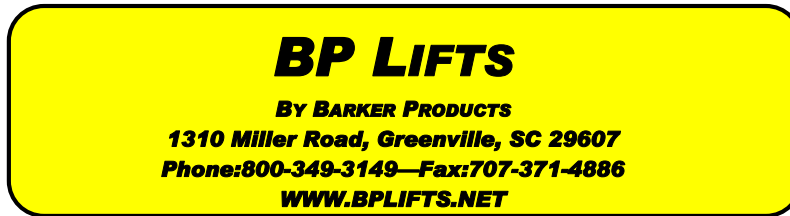

# Lift Unit Installation

1. Truck must be empty, clean and parked on a level surface before installation is started.
2. Remove all bumpers and running boards that will interfere with the location of the lift units. Relocate lower mounted tail lights as needed.
3. Measure and mark the centerline of the truck hopper. The centerline of the unit or units should be a minimum of 17" from the hopper centerline.
4. Hand valves should be mounted on the side of the hopper at the most convenient height for the operator and clear of the packer controls.
5. The top of the unit mounting plate should be tack welded in place at the height recommended on the envelope dimension sheet of the unit.  
**CAUTION: SEE NOTE BELOW PICTURE**
6. All dimensions should be approved by the customer before final welding.
7. If the mounting plate extends more than 2" above the hopper, a brace should be added.

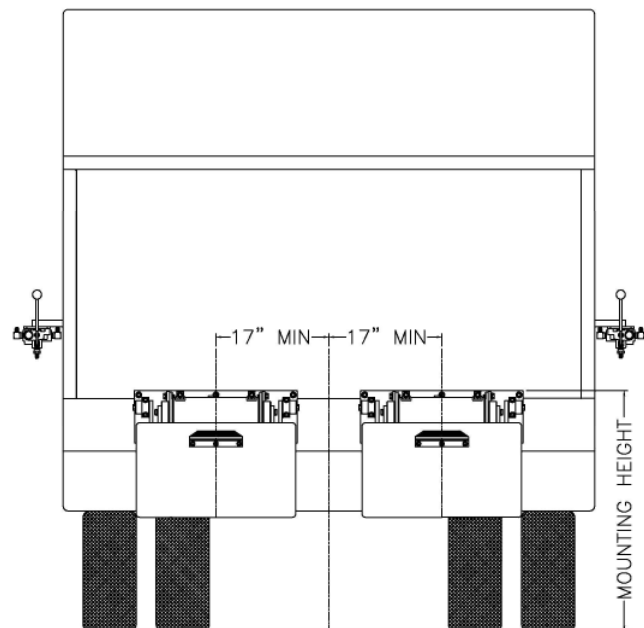

Mounting heights and locations are recommendations only. It is the responsibility of the installer to insure that the customer is satisfied with the height. Barker Products recommends that after the units are tacked in place, try the units with the can or cans the customer uses. The customer should approve your mount before final welding.

ITEM NO.	PART NUMBER	DESCRIPTION	QTY.
1	BWA18430	MAINFRAME SUB ASSY	1
2	BW18002	O-RING GREASE SEAL	2
3	BW18005	SPLINE CAP HB25	2
4	XAD081312	1/2-13 X 1 1/2 FHSCS	2
5	BW18520	HOOK LINK DRIVE SPACER	2
6	XDH081300	1/2-13 FLANGED NUT	2
7	BW99108	1/2" SPHERICAL BEARING	4
8	XEA082412SS	FLAT WASHER 1/2 X 1 1/2 X 1/8	6
9	XAA081316	1/2-13 X 2 HHCS	4
10	XAE061606	3/8-16 X 3/4 FLANGED HHCS	6
11	BWA18540	LIFT PLATE SUB ASSY	1
12	XEA062412SS	FLAT WASHER 3/8 X 1 1/2 X 1/8	4
13	BWA07490	HOOK SUB ASSY	1
14	XDA081300	1/2-13 HEX NUT	2
15	BW18620	LEFT LIFT ARM	1
16	BW18630	RIGHT LIFT ARM	1
17	BW18670	GUIDE ARM	2
18	BW18710	HOOK LINK	2

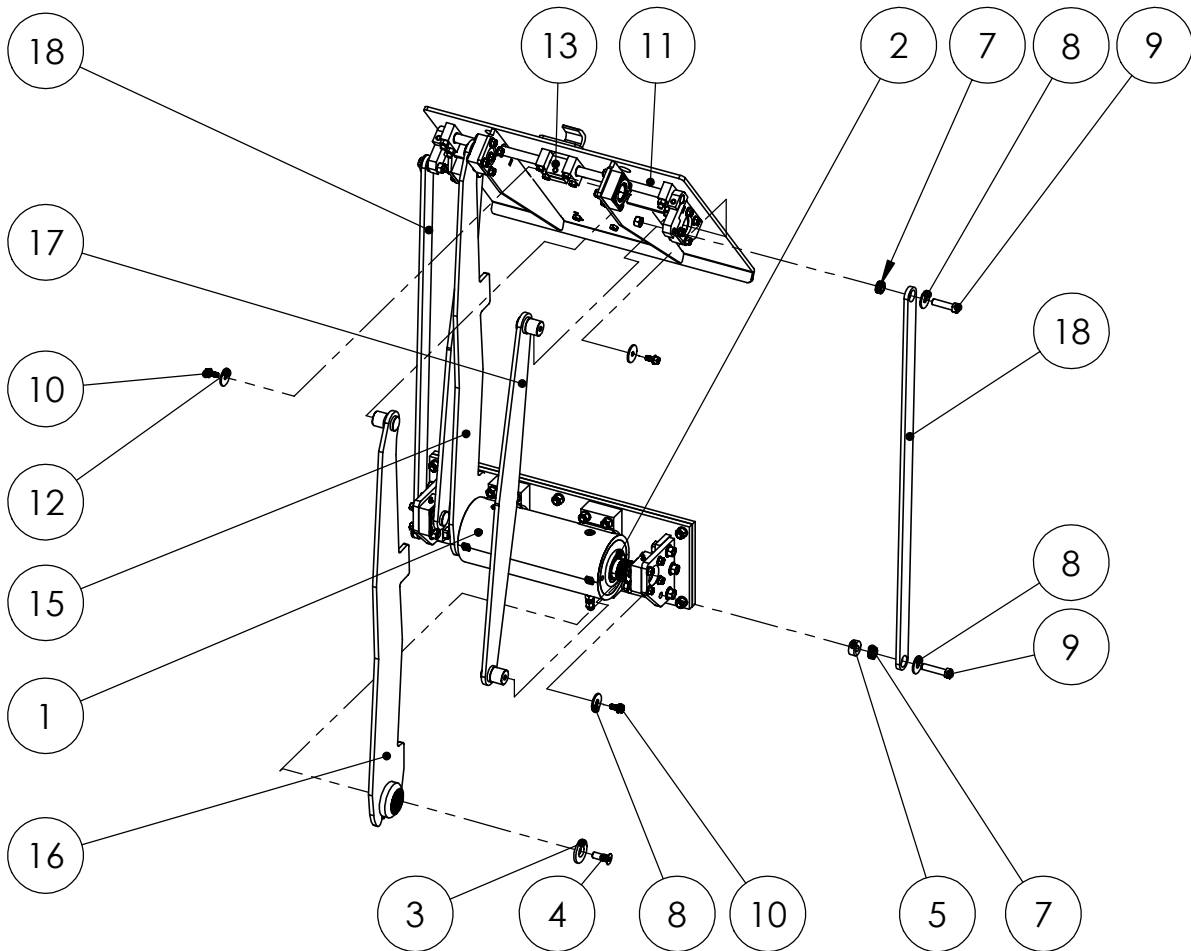

DO NOT SCALE DRAWING		BU18957 LIFT PARTS	
UNLESS OTHERWISE SPECIFIED: DIMENSIONS ARE IN INCHES TOLERANCES: FRACTIONAL ±1/32 ANGULAR: MACH ±1° BEND ±1° TWO PLACE DECIMAL ±0.010 THREE PLACE DECIMAL ±0.005		BW18400 ACTUATOR	
DRAWN BY: R WYMAN		DRAWING NO. BU18957 PARTS	
DATE: 6/1/2022		REV 00	
MATERIAL: NOTED		SCALE: 1:16	WEIGHT: 290.904 # SHEET 1 OF 1



**BARKER PRODUCTS**  
1310 MILLER ROAD  
GREENVILLE, SC  
29607

ITEM NO.	PART NUMBER	DESCRIPTION	QTY.
1	BW18506	MAINFRAME	1
2	XEB081000	1/2 LOCK WASHER	14
3	XDA082000	1/2-20 HEX NUT	14
4	BW07030	MOUNT PLATE H	1
5	BW07140	PLATE STUD	6
6	BW18510	BEARING MOUNT	2
7	XAE081312	1/2-13 X 1 1/2 FLANGED HHCS	6
8	BW18530	BEARING BODY	2
9	BW21065	PIVOT BEARING SPACER	2
10	BW99320	SPHERICAL BEARING 1 1/4	2
11	XAE061608	3/8-16 X 1 FLANGED HHCS	8
12	BV00025	116 X 1/8 NPT ORIFICE PLUG	1
13	BV00064	6T X 6S ORIFICE FITTING	1
14	BR04842	6502-06-06 MJ-FJS 45 DEG	2
15	BR03830	6400-06-06 M TUBE TO O-RING	1
16	BW07105	ACTUATOR MOUNT STUD	8
17	BW18400	ACTUATOR	1
18	BW18002	O-RING GREASE SEAL	2

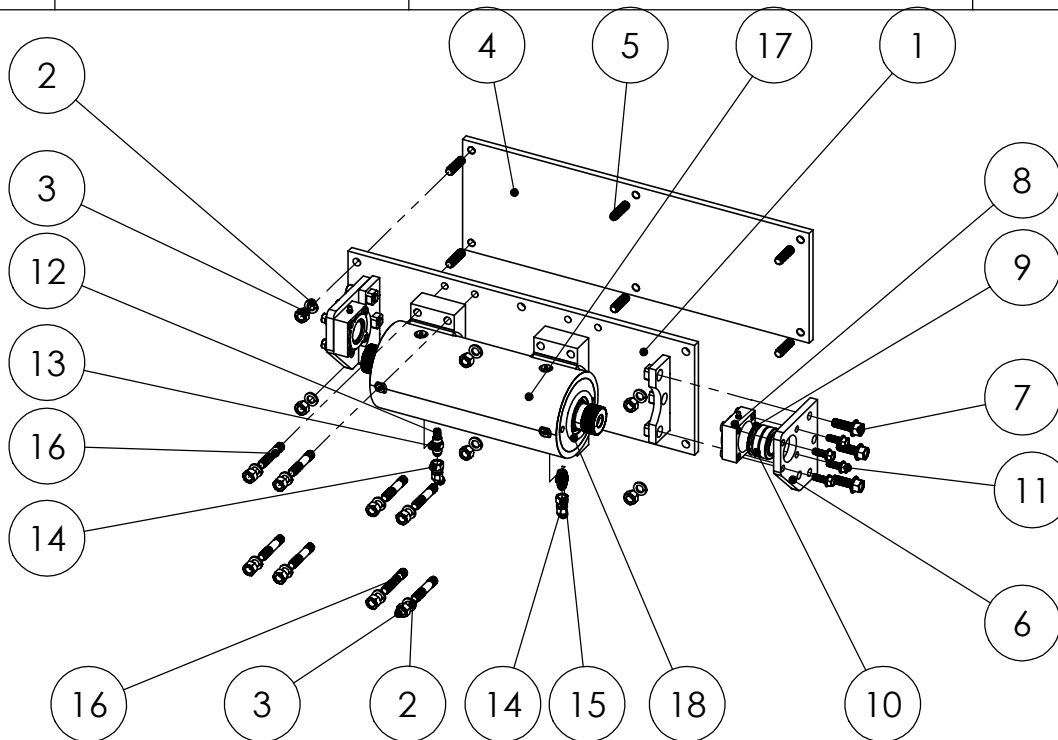

DO NOT SCALE DRAWING		MAINFRAME SUB ASSY	
UNLESS OTHERWISE SPECIFIED: DIMENSIONS ARE IN INCHES TOLERANCES: FRACTIONAL ±1/32 ANGULAR: MACH ±1° BEND ±1° TWO PLACE DECIMAL ±0.010 THREE PLACE DECIMAL ±0.005		BU189XX	
DRAWN BY: R WYMAN		DRAWING NO BWA18430 PARTS	
DATE: 6/2/2022		REV 00	
MATERIAL: NOTED		SCALE: 1:12	WEIGHT: 146.796 # SHEET 1 OF 1



**BARKER PRODUCTS**  
1310 MILLER ROAD  
GREENVILLE, SC  
29607

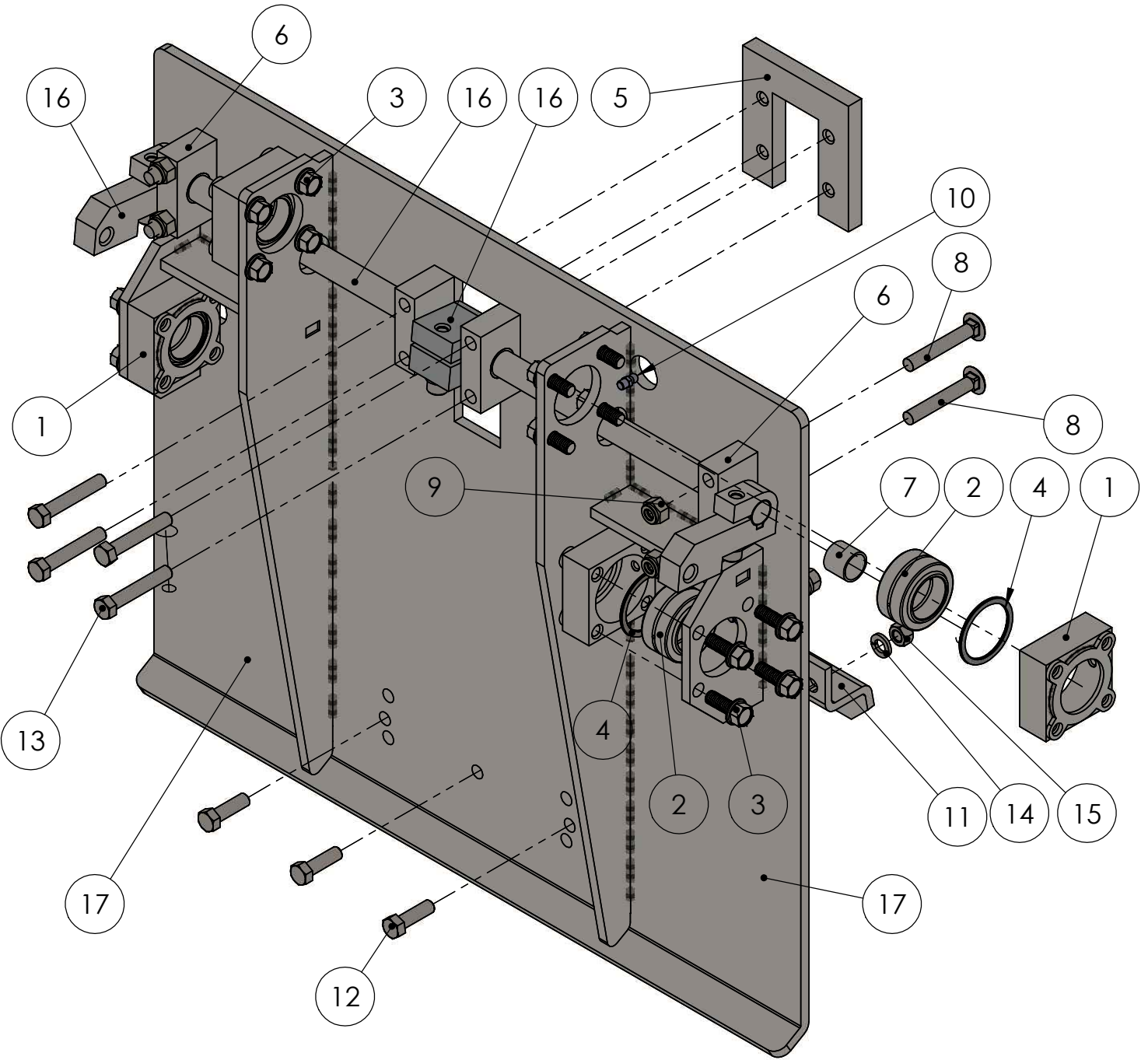

	<b>BARKER PRODUCTS</b> 1310 MILLER ROAD GREENVILLE, SC 29607		DO NOT SCALE DRAWING UNLESS OTHERWISE SPECIFIED: DIMENSIONS ARE IN INCHES TOLERANCES: FRACTIONAL $\pm 1/32$ ANGULAR: MACH $\pm 1^\circ$ BEND $\pm 1^\circ$ TWO PLACE DECIMAL $\pm 0.010$ THREE PLACE DECIMAL $\pm 0.005$	<b>LIFT PLATE SUB ASSY</b> <b>H2-25 LIFTS</b>		
	DRAWN BY: R WYMAN	DATE: 8/1/2017	MATERIAL: NOTED	DRAWING NO BWA18540	REV 01	
				SCALE: 1:4	WEIGHT: 74.297 #	SHEET 1 OF 2

ITEM NO.	PART NUMBER	DESCRIPTION	EXPLODED PARTS/QTY.
1	BW18530	BEARING BODY	4
2	BW99320	SPHERICAL BEARING 1 1/4	4
3	XAE061608	3/8-16 X 1 FLANGED HHCS	16
4	BW21065	PIVOT BEARING SPACER	4
5	BZ03451	SUPPORT PLATE	1
6	BW17130	HOOK BEARING MOUNT	4
7	BW03195	12-DU-12 BEARING	4
8	XAH061620	3/8-16 X 2 1/2 CARRIAGE BOLT	4
9	XDC061600	3/8-16 NYLOK NUT	4
10	BW01110	GREASE FITTING - 1/4-28 SHORT	4
11	BW00800	SADDLE	1
12	XAA061610	3/8-16 X 1 1/4 HHCS	3
13	XAA061618	3/8-16 X 2 1/4 HHCS	4
14	XEB061000	3/8 LOCKWASHER	3
15	XDA061600	3/8-16 HEX NUT	3
16	BWA07490	HOOK SUB ASSY	1
17	BW18540	LIFT PLATE	1



**BARKER PRODUCTS**  
1310 MILLER ROAD  
GREENVILLE, SC  
29607

DRAWN BY: R WYMAN  
DATE: 8/1/2017  
MATERIAL: NOTED

DO NOT SCALE  
DRAWING  
UNLESS OTHERWISE SPECIFIED:  
DIMENSIONS ARE IN INCHES  
TOLERANCES:  
FRACTIONAL ±1/32  
ANGULAR: MACH ±1° BEND ±1°  
TWO PLACE DECIMAL ±0.010  
THREE PLACE DECIMAL ±0.005

LIFT PLATE SUB ASSY  
H2-25 LIFTS  
DRAWING NO  
BWA18540  
SCALE: 1:6 WEIGHT: 74.297 # SHEET 2 OF 2  
REV  
01

ITEM NO.	PART NUMBER	DESCRIPTION	EXPLODED PARTS/QTY.
1	BW18550	HOOK SHAFT	1
2	BW07560	WOODRUFF KEY #806	3
3	BW07490	HOOK	1
4	BW06780	HOOK DRIVE	2
5	XEB061000	3/8 LOCKWASHER	3
6	XAB061612	3/8-16 X 1 1/2 SHCS	3

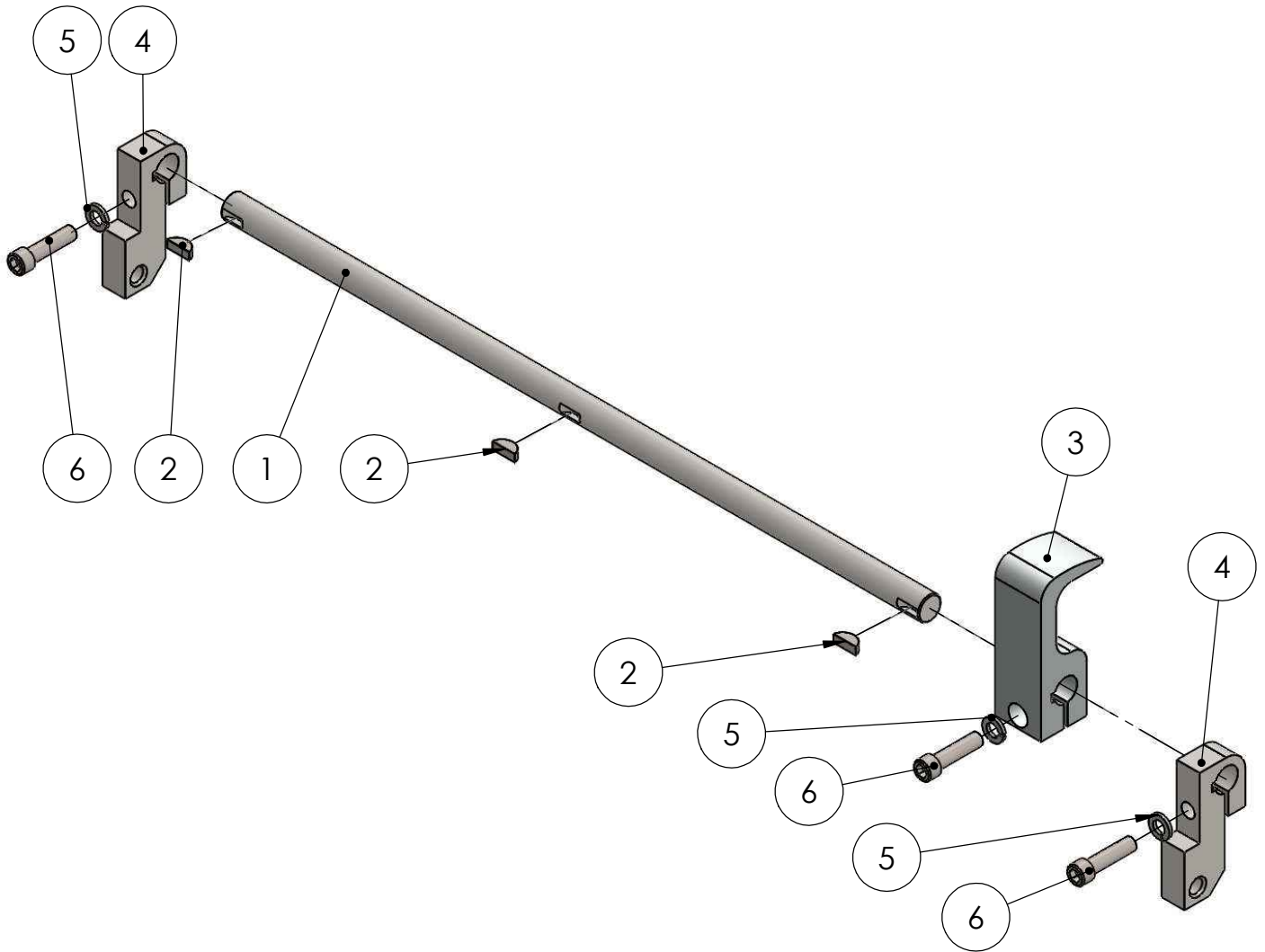

DO NOT SCALE DRAWING		HOOK SUB ASSY H2-25	
UNLESS OTHERWISE SPECIFIED: DIMENSIONS ARE IN INCHES TOLERANCES: FRACTIONAL $\pm 1/32$ ANGULAR: MACH $\pm 1^\circ$ BEND $\pm 1^\circ$ TWO PLACE DECIMAL $\pm 0.010$ THREE PLACE DECIMAL $\pm 0.005$		DRAWING NO BWA07490	REV 00
SCALE: 1:4	WEIGHT: 6.177 #	SHEET 1 OF 1	



**BARKER PRODUCTS**  
1310 MILLER ROAD  
GREENVILLE, SC  
29607

DRAWN BY: R WYMAN  
DATE: 8/1/2017  
MATERIAL: NOTED



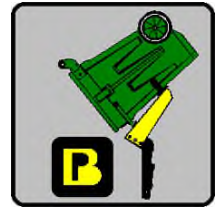
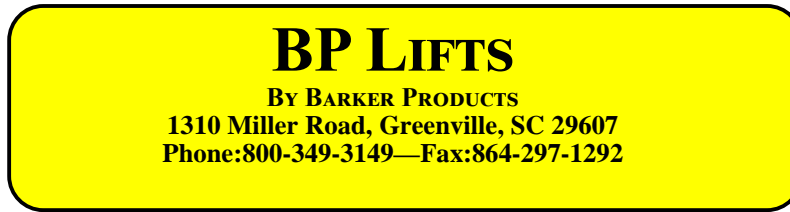

## ***BPH27-186XX SERIES LIFT UNIT WARRANTY***

**Barker Products warrants each new dump unit to be free of defects in material and workmanship under normal use and service for a period of 1 year or 2000 hours of operation, whichever comes first, from the date of delivery.**

**This warranty excludes any obligations by BARKER PRODUCTS for the cost of down time. BARKER PRODUCTS will not warranty any dump unit which has been subject to misuse, neglect, alteration, or damaged by an accident.**

**On any work not performed by BARKER PRODUCTS or it's representative, the customer will be responsible for freight charges on all parts shipped under warranty. Parts will be invoiced at time of shipment. Defective parts must be returned to BARKER PRODUCTS within 30 days. If the part is determined to be defective the customer will be credited for the original invoice.**

**Customer warranty labor charges must be approved by BARKER PRODUCTS in advance. If not contacted for approval, BARKER PRODUCTS will not be liable for the warranty labor charge.**

**Limit hydraulic input pressure to 2000PSI**