



**BP Lifts**  
By Barker Products  
1310 Miller Road, Greenville, SC 29607



# **Model BPHB27-4543 Lift**

Part # BU19343



- Dependable Smooth Acting 27K Helical Rotary Actuator
- Splined Shafts To Eliminate Arm Movement And Wear
- 50 Degree Dump Angle
- No Grease Points
- EZ Bolt On Kit Standard
- Meets ANSI Z245 Type B Specs
- Lifts All Standard American 2 Bar Carts
- Liftplate Arc Motion Makes Cart Attachment Fast And Easy On Unlevel Highway Conditions
- Double Wide Mounting Plate Available. Increases Hopper Height To Decrease Packing Cycles
- 41 to 45 Inch Mounting Height
- 23 1/8 to 25 1/8 Inch Ground Clearance
- Use on Rear Loaders with or without kick bars
- Limit Hydraulic Input Pressure To 1700 PSI

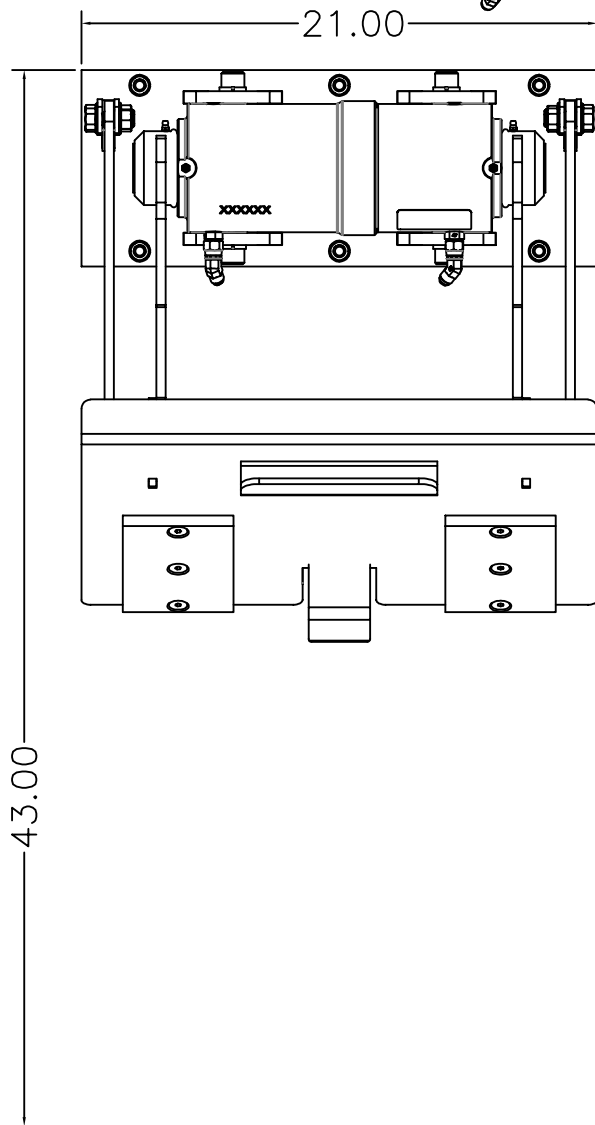
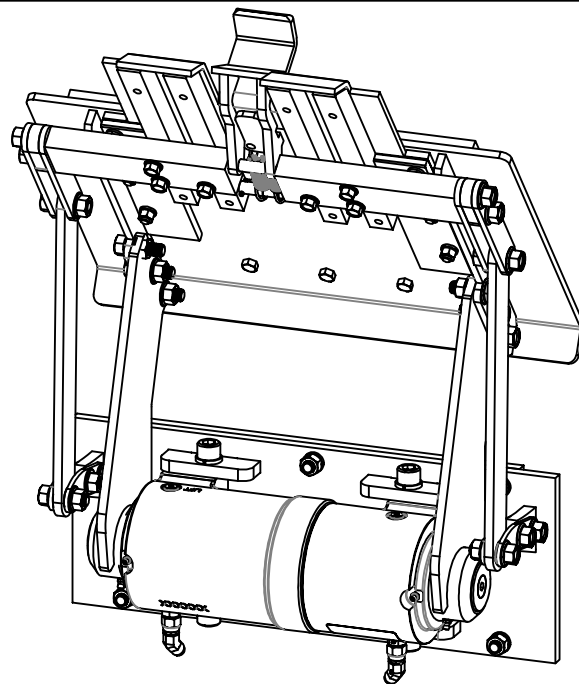
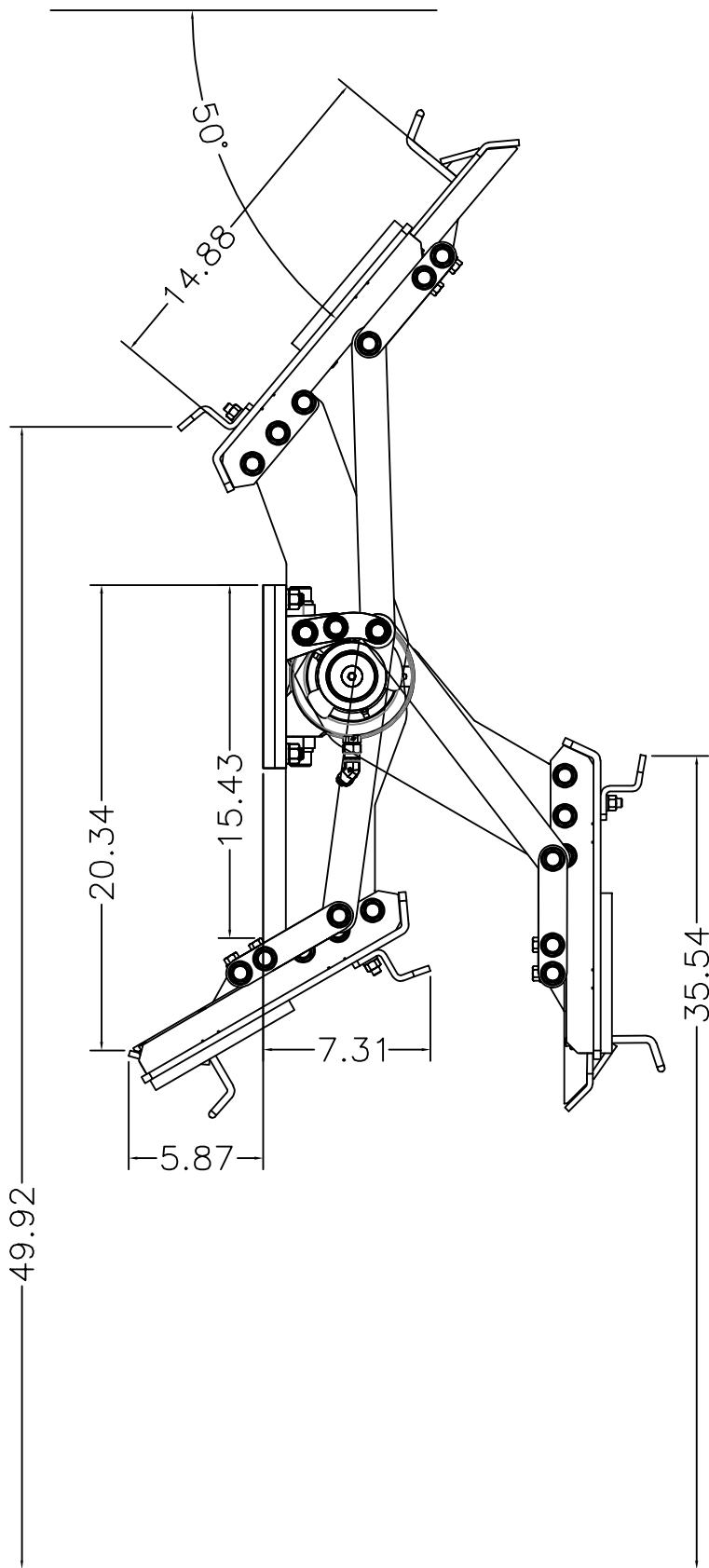

GROUND LEVEL



BARKER PRODUCTS  
1310 MILLER ROAD  
GREENVILLE, SC  
29607

DRAWN BY: R WYMAN  
DATE: 2/18/2022  
MATERIAL: NOTED

DO NOT SCALE  
DRAWING  
UNLESS OTHERWISE SPECIFIED  
DIMENSIONS ARE IN INCHES  
TOLERANCES:  
FRACTIONAL ±1/32  
ANGULAR: MACH ±1° BEND ±1°  
TWO PLACE DECIMAL ±0.010  
THREE PLACE DECIMAL ±0.005

HB27-4543  
MODEL BPHB27-4543

DRAWING NO  
BU19343 ENVELOPE

REV  
00

SCALE: 1:8 WEIGHT: 164.725 # SHEET 1 OF 1

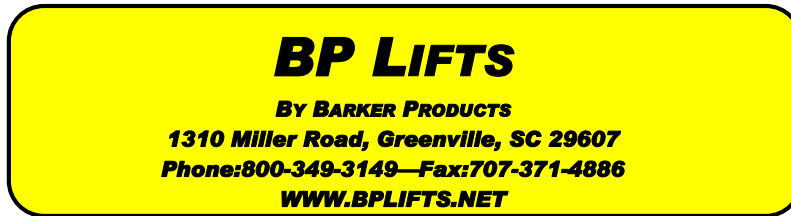

# Lift Unit Installation

1. Truck must be empty, clean and parked on a level surface before installation is started.
2. Remove all bumpers and running boards that will interfere with the location of the lift units. Relocate lower mounted tail lights as needed.
3. Measure and mark the centerline of the truck hopper. The centerline of the unit or units should be a minimum of 17" from the hopper centerline.
4. Hand valves should be mounted on the side of the hopper at the most convenient height for the operator and clear of the packer controls.
5. The top of the unit mounting plate should be tack welded in place at the height recommended on the envelope dimension sheet of the unit.  
**CAUTION: SEE NOTE BELOW PICTURE**
6. All dimensions should be approved by the customer before final welding.
7. If the mounting plate extends more than 2" above the hopper, a brace should be added.

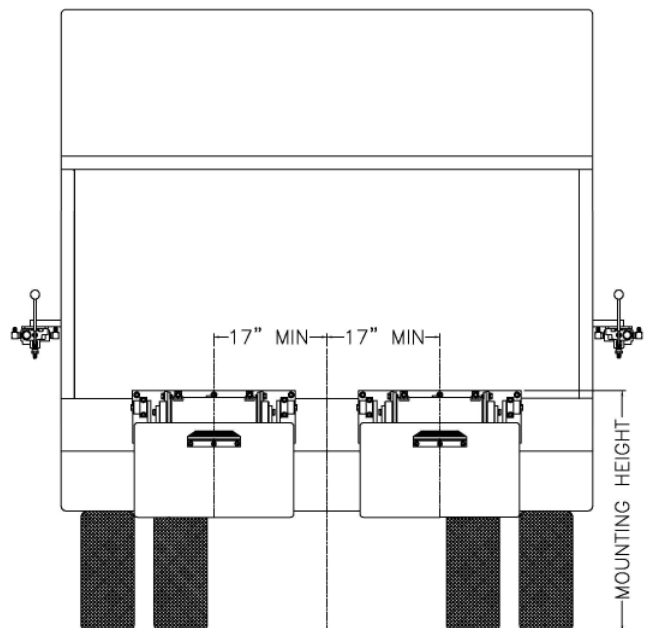

Mounting heights and locations are recommendations only. It is the responsibility of the installer to insure that the customer is satisfied with the height. Barker Products recommends that after the units are tacked in place, try the units with the can or cans the customer uses. The customer should approve your mount before final welding.

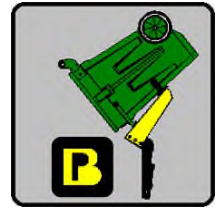
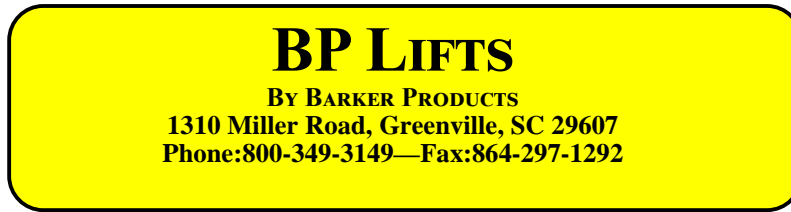

## ***BPHB27-193XX SERIES LIFT UNIT WARRANTY***

**Barker Products warrants each new dump unit to be free of defects in material and workmanship under normal use and service for a period of 1 year or 2000 hours of operation, whichever comes first, from the date of delivery.**

**This warranty excludes any obligations by BARKER PRODUCTS for the cost of down time. BARKER PRODUCTS will not warranty any dump unit which has been subject to misuse, neglect, alteration, or damaged by an accident.**

**On any work not performed by BARKER PRODUCTS or it's representative, the customer will be responsible for freight charges on all parts shipped under warranty. Parts will be invoiced at time of shipment. Defective parts must be returned to BARKER PRODUCTS within 30 days. If the part is determined to be defective the customer will be credited for the original invoice.**

**Customer warranty labor charges must be approved by BARKER PRODUCTS in advance. If not contacted for approval, BARKER PRODUCTS will not be liable for the warranty labor charge.**

**Limit hydraulic input pressure to 1700 PSI**

ITEM NO.	PART NUMBER	DESCRIPTION	QTY.
1	BWA19015	MAINFRAME SUB ASSY	1
2	BWA19290	LIFT PLATE SUB ASSY	1
3	BWA19280	SLIDE SUB ASSY	1
4	BW18050	SL PIVOT CAP	4
5	BW99108	1/2" SPHERICAL BEARING	4
6	BW18005	SPLINE CAP HB25	2
7	XAD081312	1/2-13 X 1 1/2 FHCS	2
8	XAE081312	1/2-13 X 1 1/2 FLANGED HHCS	10
9	XDH081300	1/2-13 FLANGED NUT	10
10	BW19343	LEFT LIFT ARM	1
11	BW19323	SLIDE LINK	2
12	BW19344	RIGHT LIFT ARM	1

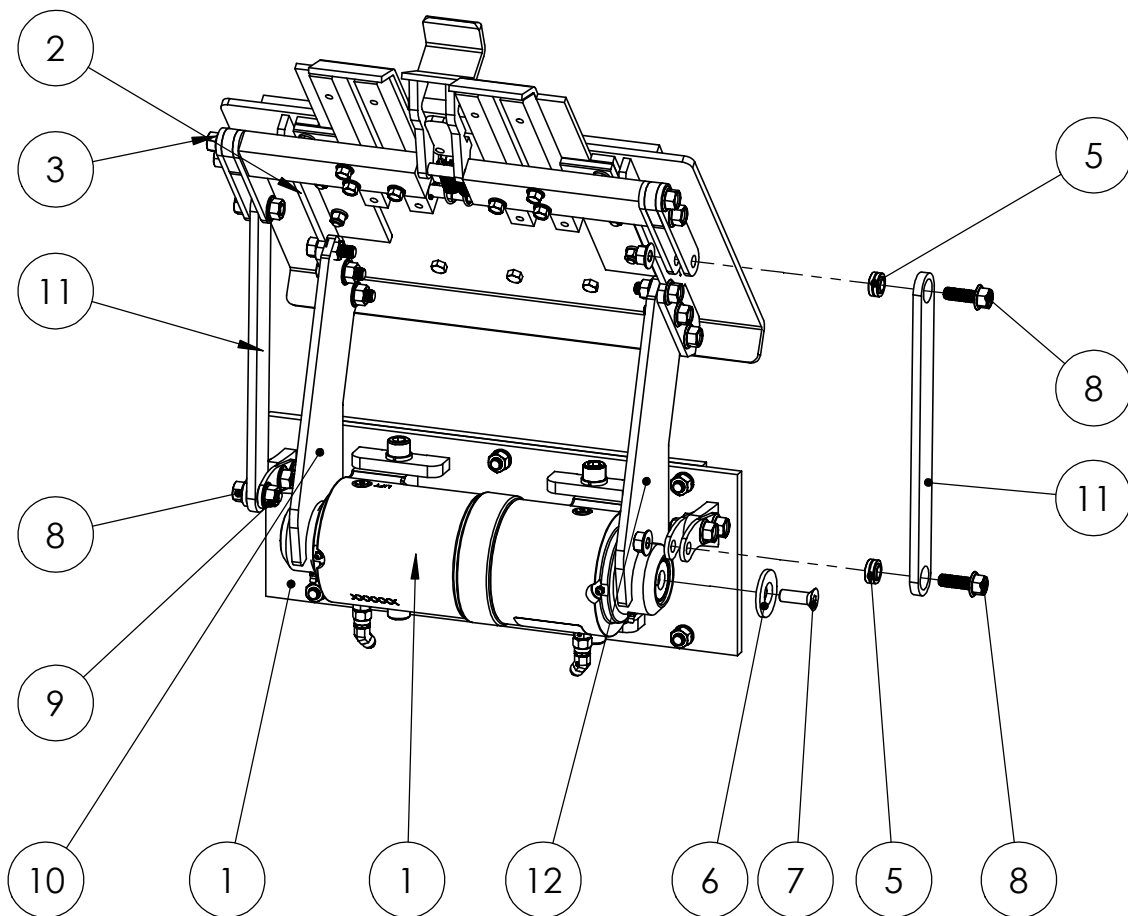

DO NOT SCALE DRAWING		HB27-45343 PARTS DWG	
UNLESS OTHERWISE SPECIFIED: DIMENSIONS ARE IN INCHES		MODEL BPHB27-4543	
TOLERANCES:		DRAWING NO	
FRACTIONAL ±1/32		BU19343 PARTS	
ANGULAR: MACH ±1° BEND ±1°		SCALE: 1:8	
TWO PLACE DECIMAL ±0.010		WEIGHT: 164.831 #	
THREE PLACE DECIMAL ±0.005		SHEET 1 OF 1	



**BARKER PRODUCTS**  
**1310 MILLER ROAD**  
**GREENVILLE, SC**  
**29607**

DRAWN BY: R WYMAN  
DATE: 2/24/2022  
MATERIAL: NOTED

REV  
00

ITEM NO.	PART NUMBER	DESCRIPTION	QTY.
1	BW19015	MAINFRAME	1
2	BW18002	O-RING GREASE SEAL	2
3	BW17525	MOUNT PLATE - N	1
4	BW18050	SL PIVOT CAP	4
5	XEB081000	1/2 LOCK WASHER	6
6	XAB101110	5/8-11 X 1 1/4 SHCS	4
7	BV00064	6T X 6S ORIFICE FITTING	1
8	BV00025	116 X 1/8 NPT ORIFICE PLUG	2
9	BR04842	6502-06-06 MJ-FJS 45 DEG	2
10	BR03830	6400-06-06 M TUBE TO O-RING	1
11	BW07140	PLATE STUD	6
12	XDA082000	1/2-20 HEX NUT	6
13	XAE081312	1/2-13 X 1 1/2 FLANGED HHCS	4
14	XDH081300	1/2-13 FLANGED NUT	4
15	BW18300	27K HELICAL ACTUATOR	1
16	XEB101000	5/8 LOCKWASHER	4

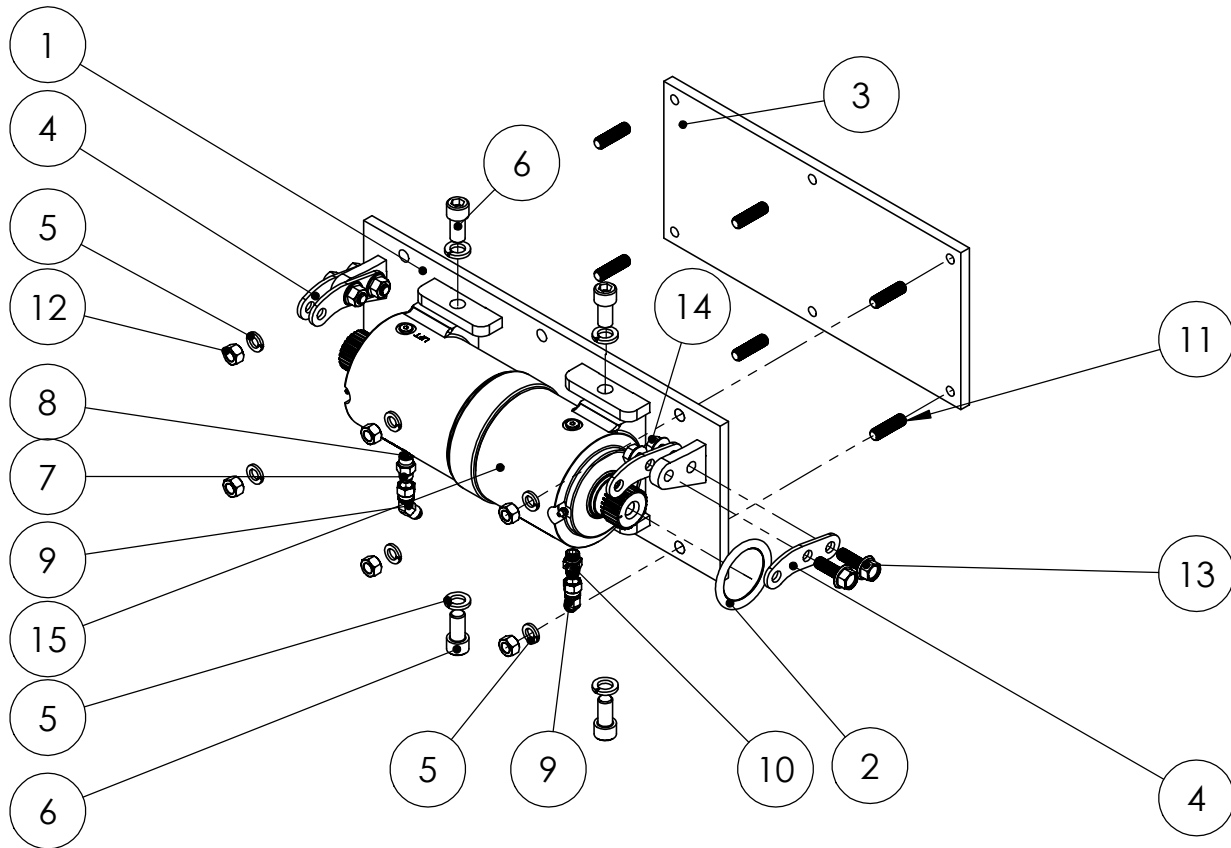

DO NOT SCALE DRAWING		MAINFRAME SUB ASSY BU19XXX	
UNLESS OTHERWISE SPECIFIED: DIMENSIONS ARE IN INCHES TOLERANCES: FRACTIONAL $\pm 1/32$ ANGULAR: MACH $\pm 1^\circ$ BEND $\pm 1^\circ$ TWO PLACE DECIMAL $\pm 0.010$ THREE PLACE DECIMAL $\pm 0.005$		DRAWING NO BWA19015 PARTS	REV 00
SCALE: 1:8	WEIGHT: 72.623 #	SHEET 1 OF 1	



**BARKER PRODUCTS**  
1310 MILLER ROAD  
GREENVILLE, SC  
29607

DRAWN BY: R WYMAN  
DATE: 2/23/2022  
MATERIAL: NOTED

ITEM NO.	PART NUMBER	DESCRIPTION	QTY.
1	BW19290	LIFT PLATE	1
2	BW00800	SADDLE	1
3	XEA061000	3/8 LOCKWASHER	9
4	XDA061600	3/8-16 HEX NUT	9
5	BW10675	CAN SUPPORT	2
6	XAD061616	3/8-16 X 2 FSHCS	6
7	BW19110	SLIDE SPACER	2
8	BW19100	SLIDE CAP	2
9	XAA061610	3/8-16 X 1 1/4 HHCS	3

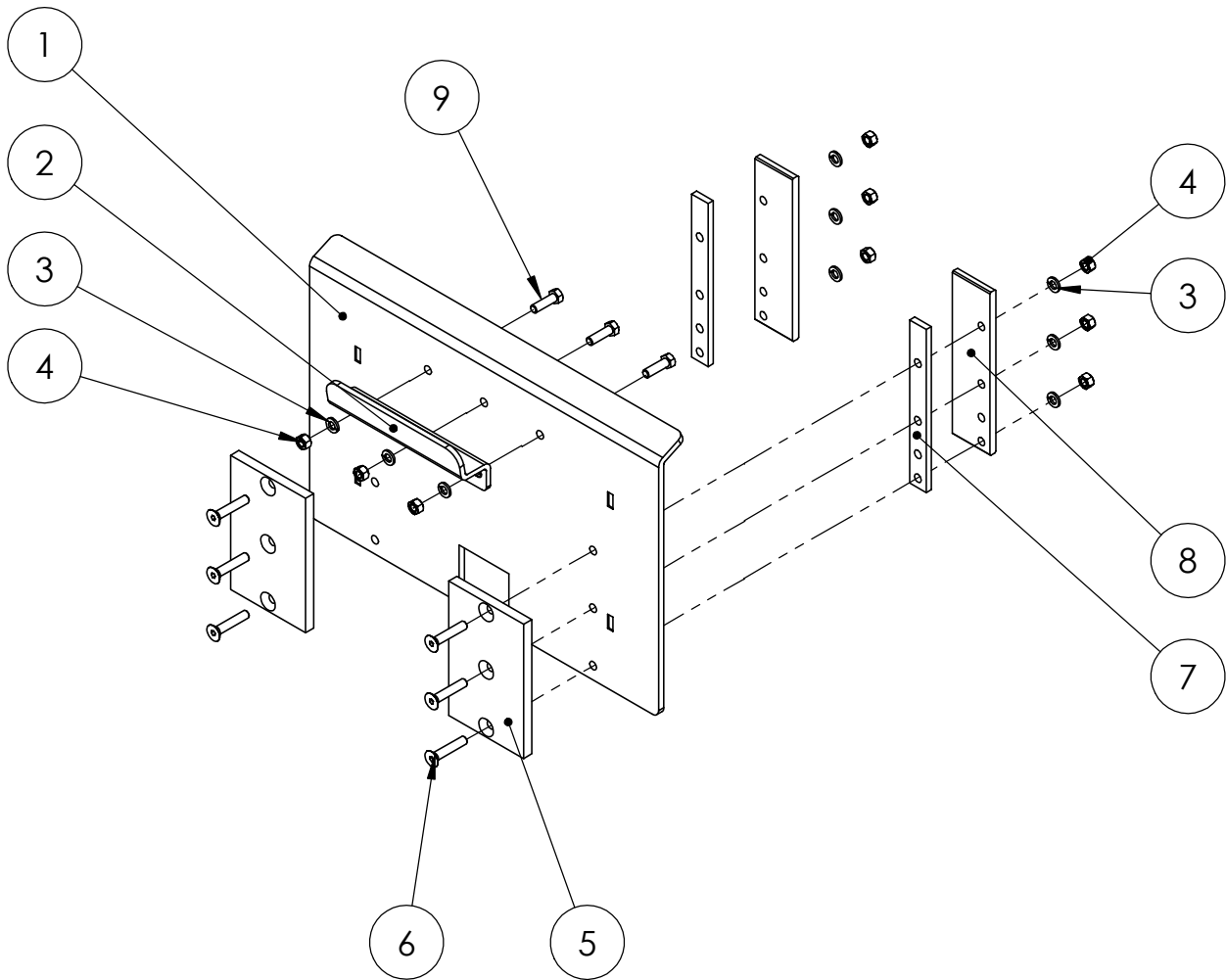

**BARKER PRODUCTS**  
**1310 MILLER ROAD**  
**GREENVILLE, SC**  
**29607**

DRAWN BY: R WYMAN  
DATE: 2/24/2022  
MATERIAL: NOTED

DO NOT SCALE  
DRAWING  
UNLESS OTHERWISE SPECIFIED:  
DIMENSIONS ARE IN INCHES  
TOLERANCES:  
FRACTIONAL ±1/32  
ANGULAR: MACH ±1° BEND ±1°  
TWO PLACE DECIMAL ±0.010  
THREE PLACE DECIMAL ±0.005

LIFT PLATE SUB ASSY

DRAWING NO  
BWA19290

REV  
00

SCALE: 1:8

WEIGHT: 38.632 #

SHEET 1 OF 1

ITEM NO.	PART NUMBER	DESCRIPTION	QTY.
1	BW10230	SLIDE PLATE	1
2	XAD061606	3/8-16 X 3/4 FHSCS	12
3	BW10240	SLIDE SUPPORT	4
4	BW10100	HOOK SHAFT	1
5	BW10110	SPRING SHAFT	1
6	BW02125	5/32 X 3/4 SPRING PIN	2
7	BW10120	HOOK SPRING	2
8	BW19285	SLIDE DRIVE	2
9	BW10680	LOWER HOOK	1
10	BW19286	SLIDE DRIVE EXTENSION	4
11	BW19287	EXTENSION SPACER	2
12	XAE061612	3/8-16 X 1 FLANGED HHCS	6
13	XAE081312	1/2-13 X 1 1/2 FLANGED HHCS	4

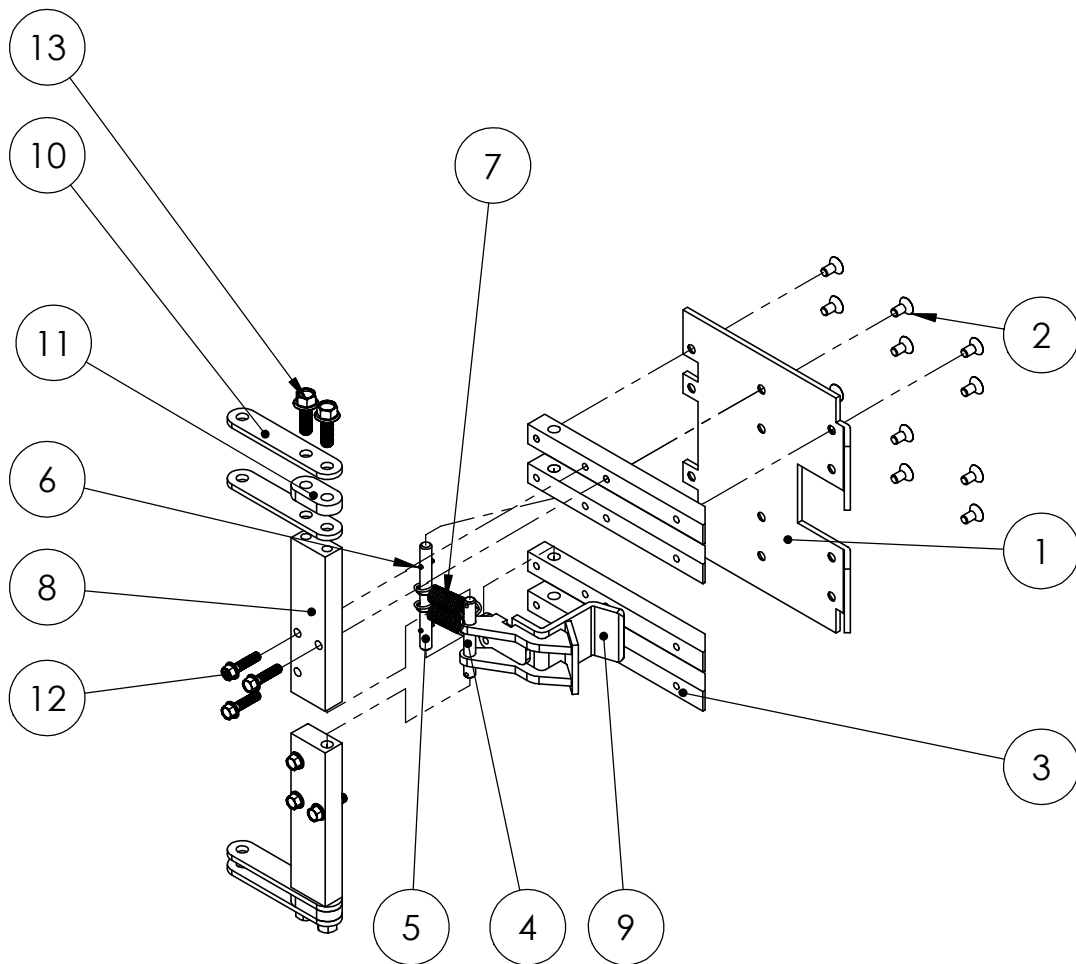

DO NOT SCALE DRAWING		SLIDE SUB ASSY BU19X39	
UNLESS OTHERWISE SPECIFIED: DIMENSIONS ARE IN INCHES TOLERANCES: FRACTIONAL ±1/32 ANGULAR: MACH ±1° BEND ±1° TWO PLACE DECIMAL ±0.010 THREE PLACE DECIMAL ±0.005		DRAWING NO BWA19280	REV 00
SCALE: 1:8		WEIGHT: 32.629 #	SHEET 1 OF 1



**BARKER PRODUCTS**  
1310 MILLER ROAD  
GREENVILLE, SC  
29607

DRAWN BY: R WYMAN  
DATE: 2/24/2022  
MATERIAL: NOTED